

NIBE F470

Exhaust air heat pump

Complete heat pump unit that provides heating, hot water, ventilation, heated supply air and heat recovery



- Display unit with easy-to-read colour screen.
- It also gives you the opportunity to control comfort in your home no matter where you are by using NIBE Uplink.
- Great savings thanks to the large compressor, which, with intelligent control, works with the current most favourable temperature conditions.
- Low energy circulation pump, class A, and low energy fans.
- Outdoor and room sensors.
- Measures and logs average indoor temperature during the heating season.
- Scheduling heating, ventilation and hot water as well as holiday mode.
- Uses an environmentally-friendly R290 refrigerant.
- Can control several heating systems, with different temperature levels.
- Phase individual load monitor.
- Considerable energy savings compared to the FTX unit, for example, because the recovered energy is also used for the hot water and the waterborne heating system.
- Compact and good value complete system with ventilation, hot water and heating, all in the same product

F470 is a complete exhaust and supply air heat pump for both new installations and replacement in houses or similar. F470 can be used in low energy/passive houses, where exhaust and supply ventilation in combination with energy efficient hot water heating is required.

 **NIBE**

A⁺

The system's efficiency class for heating.

A



L

The product's efficiency class and tap profile for hot water.

This is how F470 works

Principle

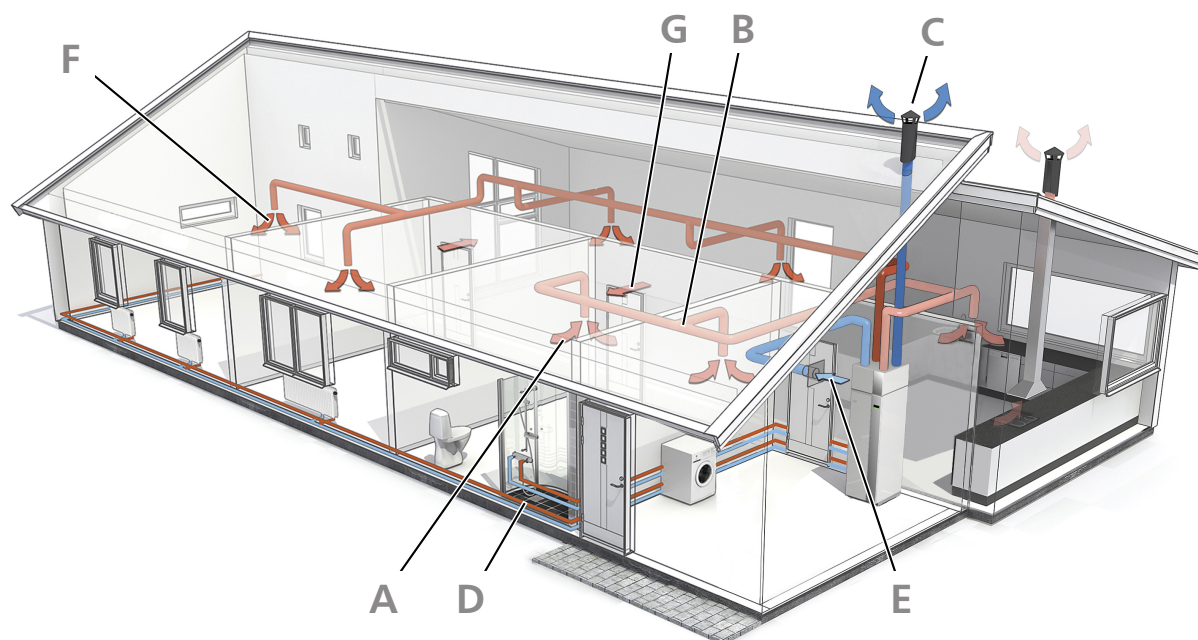

F470 is an exhaust air heat pump with supply air coil, integrated DC fans and a water heater that has copper or stainless steel corrosion protection. In addition, it has an integrated immersion heater.

Energy is recovered from the ventilation air and supplied to the heat pump, which reduces energy costs considerably. The device ventilates the house, supplies heat and produces domestic hot water. F470 is intended for low-temperature dimensioned radiator circuits and/or underfloor heating.

The unit is intended for both new installations and replacement in houses or similar.

Within the accessories, F470 can be docked to other heat sources such as district heating.

- A** The warm room air is drawn into the air duct system.
- B** The warm room air is fed to F470.
- C** The room air is released when it has passed F470. The air temperature has then been reduced as F470 has extracted the energy in the room air.
- D** F470 supplies the house with both hot water and room heating.
- E** Outdoor air is drawn into F470 and heated if necessary.
- F** Air is blown out into rooms with supply air inlets.
- G** Air is transported from rooms with supply air inlets to rooms with exhaust air valves.

Design

Control of F470 is designed to ensure easy operation while always enabling the heat pump to run as efficiently as possible. F470 decides on the best operation mode and is able to control several climate systems when several different supply temperatures are required. The display shows the current temperatures and set values in plain text.

The design of the ventilation section gives a high ventilation capacity. The steplessly adjustable fans can also easily be increased or reduced via the display unit or an external signal.

F470 gives great savings thanks to a powerful compressor, which, with intelligent control, works with the current most favourable temperature conditions.

The insulation consists of moulded Neopor (environmentally friendly cellular plastic) for minimal heat loss.

The outer casing is of white powder-coated steel plate. The front door is easy to remove for easy access when installing and for servicing.

F470 has a maximum immersion heater output of 9.25 kW. The output is easy to adjust via the display and can be blocked.

Principle of operation, cooling circuit

When the exhaust air at room temperature passes through the evaporator, the refrigerant evaporates because of its low boiling point. In this way the energy in the room air is transferred to the refrigerant.

The refrigerant is then compressed in a compressor, causing the temperature to rise considerably.

The warm refrigerant is led to the condenser. Here the refrigerant gives off its energy to the heating system water, whereupon the refrigerant changes state from gas to liquid.

The refrigerant then goes via filters to the expansion valve, where the pressure and temperature are reduced.

The refrigerant has now completed its circulation and returns to the evaporator.

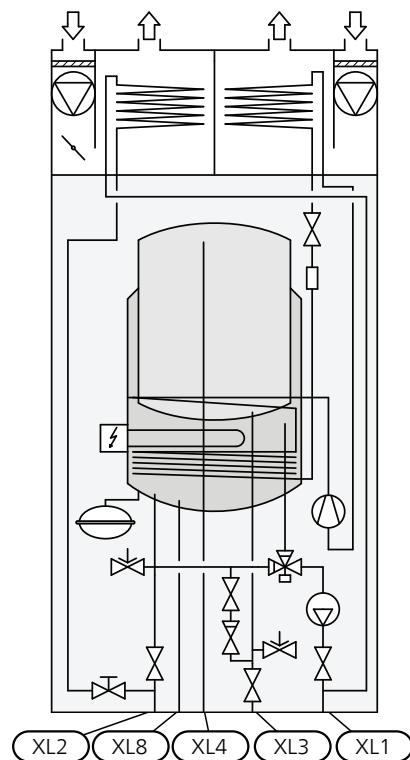

- | | |
|-----|-----------------------------------|
| XL1 | Connection, heating medium flow |
| XL2 | Connection, heating medium return |
| XL3 | Connection, cold water |
| XL4 | Connection, hot water |
| XL8 | Connection, docking |



Caution This is an outline diagram, differences may occur in the actual installation.

Good to know about F470

Transport and storage

F470 should be transported and stored vertically in a dry place. The F470 may, however, be carefully laid on its back when being moved into a building.

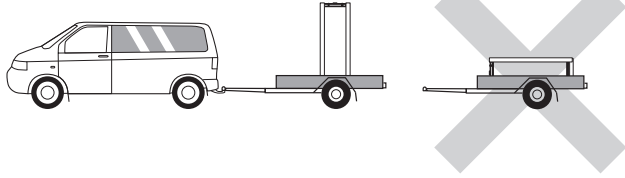

Supplied components

Local differences in the enclosed kit may occur. See relevant installer manual for more information.

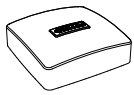

Outside sensor

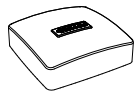

Room sensor



Earth cabling (4 pcs)



Current sensor

Location

The kit of supplied items is placed on top of the product.

Installation and positioning

- Position F470 on a fixed foundation that can take the weight of the heat pump.

Because water comes from F470, the floor coating is important. A waterproof floor or floor membrane is recommended.

- Because water comes from F470, it is good if the area where the heating pump is located is provided with floor drainage.
- Install with its back to an outside wall, ideally in a room where noise does not matter, in order to eliminate noise problems. If this is not possible, avoid placing it against a wall behind a bedroom or other room where noise may be a problem.
- Wherever the unit is located, walls to sound sensitive rooms should be fitted with sound insulation.
- Route pipes so they are not fixed to an internal wall that backs on to a bedroom or living room.
- The heat pump's installation area should always have a temperature of at least 10 °C and max 30 °C.

Installation area

Leave a free space of 800 mm in front of the product. Leave free space between F470 and wall/other machinery/fittings/cables/pipes etc. It is recommended that a space of at least 10 mm is left to reduce the risk of noise and of any vibrations being propagated.

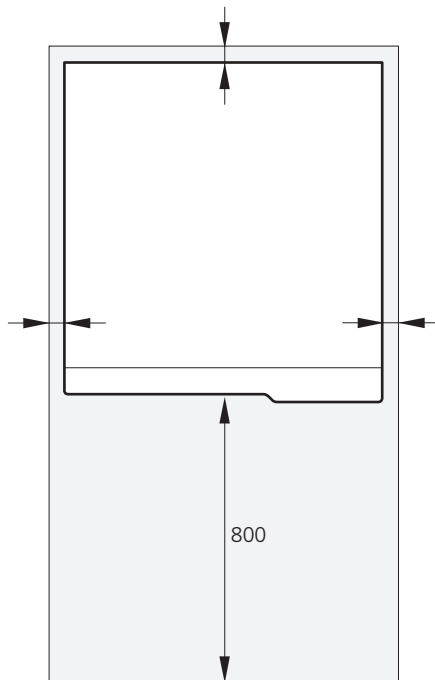

NOTE Ensure that there is sufficient space (300 mm) above the heat pump for installing ventilation hoses.

Installation

Equipment

F470 is equipped with climate-controlled heating control system with outdoor temperature, room temperature and supply temperature sensors, circulation pump, load monitor and expansion vessel. For the heating section, F470 copper and stainless steel equipped with safety and filler valve. The hot water section in F470 copper and stainless steel is equipped with a set of valves comprising filler, mixing, non-return and safety valves.

Maximum boiler and radiator volumes

The volume of the pressure expansion vessel is 10 litres and it is pre-pressurised as standard to 0.5 bar (5 mvp). As a result, the maximum permitted height between the vessel and the highest radiator is 5 metres. There is a valve on the vessel for any pre-pressure adjustment.

The pre-pressure of the expansion vessel must be stated in the inspection document.

The maximum system volume excluding the boiler is 219 litres at the above pre-pressure.

Inspection

F470 is equipped with a closed expansion vessel as standard. National standards can assert that the boiler installation must be inspected before it is taken into use. This inspection may only be performed by persons with the necessary expertise.

National regulations can assert that the function of the ventilation system must be checked. This check may only be carried out by an authorised person.

Pipe installation

Pipe installation must be carried out in accordance with current norms and directives.

Pipe connections for cold and hot water as well as supply and return lines are fitted with 22 mm compression ring couplings.

Connecting the heating system

When the circulation pump is operating, the flow in the heating system must not be stopped completely, i.e. at least one of the heating system's radiators/underfloor heating coils must be fully open.

Available external pressure, heating system

Capacity, circulation pump (CP)

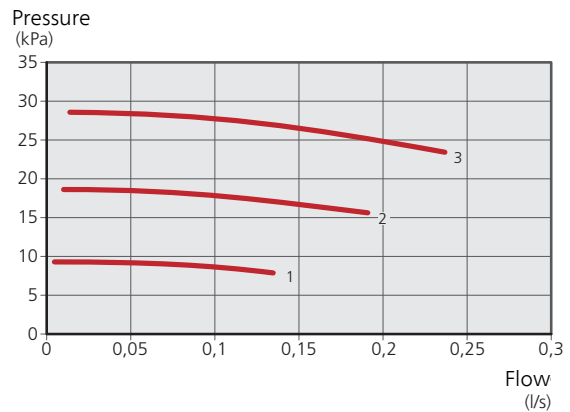

Tap water connection

The heat pump should be supplemented with an extra water heater, if a large bath tub or other significant consumer of hot water is installed.

Water heater with immersion heater

If it is possible to use a water heater with an immersion heater, connect it as illustrated below.

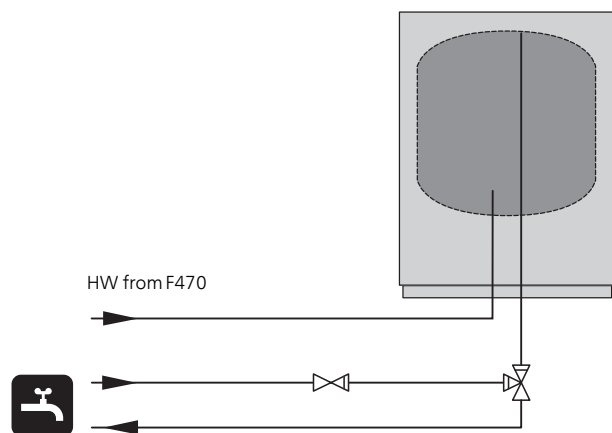

For more information see www.nibe.eu.

Ventilation

Connect F470 so that all of the exhaust air, except kitchen duct air (kitchen fan), passes the evaporator in the heat pump. The lowest ventilation flow must comply with the applicable national standards. For optimum heat pump performance, the ventilation flow should not be less than 28 l/s (100 m³/h) at an exhaust air temperature of at least 20°C. When the exhaust air temperature is lower than 20°C (for example at start-up and when there is nobody at home), the minimum value is 31 l/s (110 m³/h). The supply air flow must be lower than the exhaust air flow to prevent over pressure in the house.

The heat pump's installation area must be ventilated to at least 5 l/s (18 m³/h)

If the exhaust air temperature falls below 16 °C, the compressor is blocked and electric additional heat is permitted. Heat is not recovered from the exhaust air when the compressor is blocked.

To prevent fan noise being transferred to the ventilation devices, install silencers in the ducts.

Connections must be made via flexible hoses, which should be installed so that they are easy to replace. When the extract air and outdoor air temperature becomes cold, the extract air and outdoor air duct must be insulated using diffusion-proof material (PE30) along its entire length. Exhaust air ducts that are routed in cold areas must be insulated. All joints in the ducting must be sealed and should be screwed/pop-riveted to prevent leakage. The duct system must be a minimum of air tightness class B. The extract air duct must be a maximum of 20 m long with a maximum of six bends.

Because the heat pump contains the flammable refrigerant propane (R290), the air ducting system must be earthed. This is achieved by making a good electrical connection to the four ventilation ducts using the enclosed earth cables (4 pcs).

Exhaust air duct (kitchen fan) must not be connected to F470. A duct in a masonry chimney stack must not be used for extract air.

If a stove or similar is installed, it must have airtight doors and take combustion air from outside.

Incorrect ventilation adjustment may lead to reduced installation efficiency and thus poorer operating economy, and may result in moisture damage to the house.

Setting the fan capacity

Select the ventilation capacity steplessly in the display.

Ventilation capacity, supply air

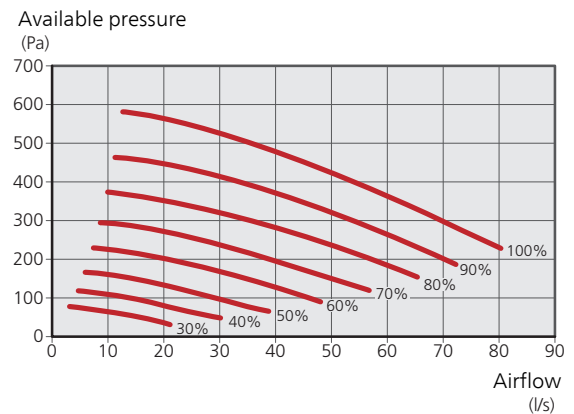

Ventilation capacity, exhaust air

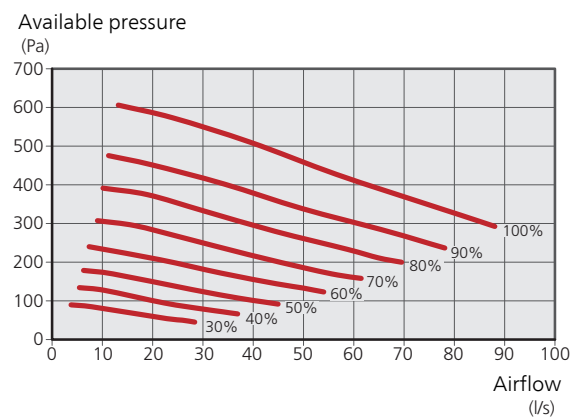

Electrical connections

Connection must not be carried out without the permission of the electricity supplier and must be under the supervision of a qualified electrician.

F470 must be connected with corresponding connection cable (length approx. 2 m) via an isolator switch with a minimum breaking gap of 3 mm. Minimum cable area must be sized according to the fuse rating used. The connection cable can be found on the reverse of F470 (see dimensions diagram below).

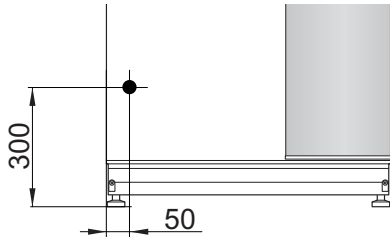

All electrical equipment, except the outdoor temperature sensors, room sensors and the current sensors, is already connected at the factory.

Operation (230 V), fans and circulation pump are internally fused by a miniature circuit breaker (10 A).

3x400V copper

Electrical addition (kW)	Max (A) L1	Max (A) L2	Max (A) L3
0.0	6.3	-	-
2.0	6.3	-	8.7
3.7	6.3	7.3	8.7
4.6*	6.3	8.4	11.6
7.0	17.9	7.3	11.6
9.3	17.9	8.4	20.3

*Factory setting

The table displays the maximum phase current for the relevant power step for the heat pump.

3x400V stainless steel

Electrical addition (kW)	Max (A) L1	Max (A) L2	Max (A) L3
0.0	6.3	-	-
2.0	6.3	-	8.7
4.7	6.3	11.6	8.7
5.6*	6.3	11.6	11.6
8.0	17.9	11.6	11.6
10.3	17.9	12.7	20.3

*Factory setting

The table displays the maximum phase current for the relevant power step for the heat pump.

3x230V

Electrical addition (kW)	Max (A) L1	Max (A) L2	Max (A) L3
0.0	4.5	4.5	-
2.0	4.5	11.6	8.7
4.7	14.4	11.6	17.6
6.7*	14.4	20.0	25.3
8.0	24.1	24.1	20.1
10.0	24.1	31.6	28.0

*Factory setting

The table displays the maximum phase current for the relevant power step for the heat pump.

1x230V

Electrical addition (kW)	Max (A)
0.0	6.3
2.7	17.9
5.3*	29.3
8.0	41

*Factory setting

The table displays the maximum phase current for the relevant power step for the heat pump.

Outdoor and room sensors

Connect the sensors with two-core cable to terminal block. The minimum cable cross-section should be 0.4 mm² up to 50 metres, for example EKXX or LiYY.

Install the outdoor temperature sensor in the shade on a wall facing north or north-west, so it is unaffected by the morning sun. If a cable duct is used, it must be sealed to prevent condensation in the sensor capsule.

Install the room sensor in a neutral location where the displayed temperature is required.

External control and load monitor.

In cases where an external control is required, it can be connected to a terminal block.

F470 is equipped with two types of integrated load monitors. The basic monitor calculates whether future immersion heater steps can be connected without the specified main fuse tripping. The more advanced monitor is used together with the enclosed current sensors, which are installed in the electrical distribution unit and connected to a terminal block in F470.

If the current sensors are connected, F470 monitors the phase currents in the building and allocates the power steps automatically to the least loaded phase.

Functions

Control, general

The indoor temperature depends on several different factors. Sunlight and heat emissions from people and household machines are normally sufficient to keep the house warm during the warmer parts of the year. When it gets colder outside, the climate system must be started. The colder it is outside, the warmer radiators and under floor heating system must be.

Control of the heat production is performed based on the "floating condensing" principle, which means that the temperature level needed for heating at a specific outdoor temperature is produced based on collected values from the outdoor and supply temperature sensors. The room sensor can also be used to compensate the deviation in room temperature.

Heat production



The supply of heat to the house is regulated in accordance with the heating curve setting selected. After adjustment, the correct amount of heat for the outdoor temperature is supplied. The supply temperature of the heat pump will hover around the theoretically required value.

Own curve

F470 has pre-programmed non-linear heating curves. It is also possible to create your own defined curve. This is an individual linear curve with a number of break points. You select break points and the associated temperatures.

Hot water production



Hot water charging starts when the temperature has fallen to the set start temperature. Hot water charging stops when the hot water temperature at the hot water sensor has been reached.

For occasional higher hot water demand, there is a function called "temporary lux" that allows the temperature to be raised via one time increase or up to 12 hours (selected in the menu system).

Additional heat only

F470 can be used with only additional heat (electric boiler) to produce heating and hot water, for example, before the ventilation system is complete.

Alarm indications

The status lamp lights red in the event of an alarm and the display shows detailed information depending on the fault. An alarm log is created with each alarm containing a number of temperatures, times and operating status.

The display

F470 is controlled using a clear and easy to use display.

Instructions, settings and operational information are shown on the display. You can easily navigate between the different menus and options to set the comfort or obtain the information you require.

The display unit is equipped with a USB socket that can be used to update the software, save logged information and manage the settings in F470.

Visit www.nibeuplink.com and click the "Software" tab to download the latest software for your installation.

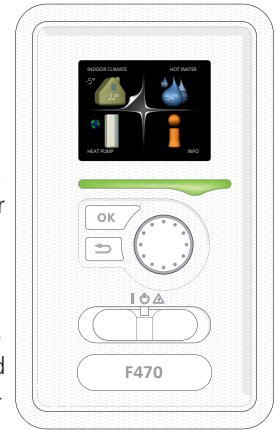

NIBE Uplink



Using the Internet and NIBE Uplink, you can obtain a quick overview and the present status of the installation and the heating in your home. You can obtain a good overall view where you can monitor and control the heating and hot water comfort. If the system is affected by a malfunction, you receive an alert via e-mail that allows you to react quickly.

NIBE Uplink also gives you the opportunity to control the comfort in your home easily, no matter where you are.

Range of services

You have access to different levels of service via NIBE Uplink. A basic level that is free and a premium level where you can select different extended service functions for a fixed annual subscription fee (the subscription fee varies depending on the selected functions).

NIBE Uplink also available as an app from App Store and Google Play.

Installation and associated equipment requirements

The following is required in order for NIBE Uplink to function with the installation:

- Network cable Cat.5e UTP (straight, male-male), wired network communication.
- Internet connection (broadband).
- Web browser that supports JavaScript. If Internet Explorer is used, it should be version 7 or higher. See the help file in the web browser for information on how to activate JavaScript.

If it is not possible to connect to NIBE Uplink, F470 can be controlled remotely via SMS. For this, the accessory SMS 40 is required.

For further presentation, visit www.nibeuplink.com.

Technical data

Dimensions

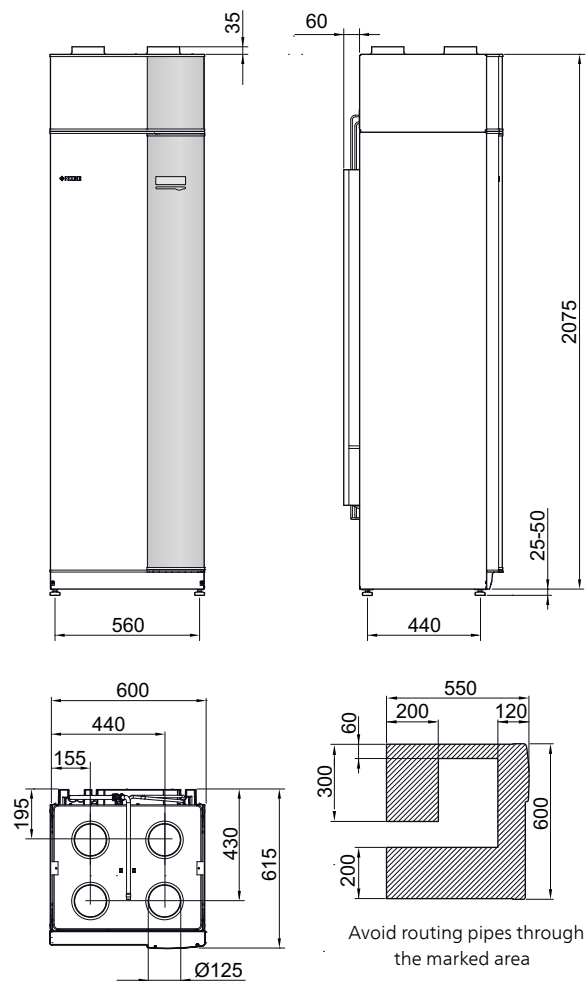

Pipe connections

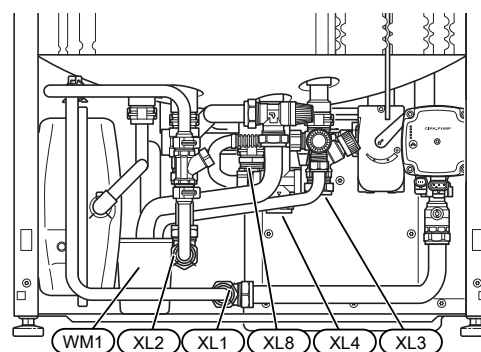
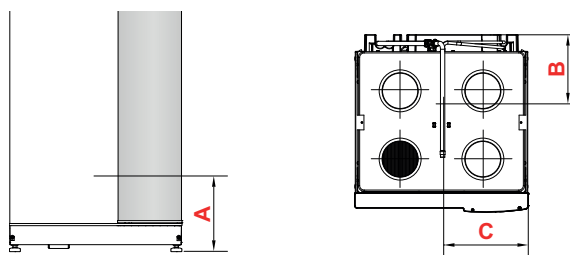

Setting out dimensions

Copper

Connection		A	B	C
XL1 Heating medium supply	(mm)	50	415	335
XL2 Heating medium return	(mm)	100	410	385
XL3 Cold water	(mm)	200	455	215
XL4 Hot water	(mm)	180	405	265
XL8 Docking	(mm)	220	290	300
WM1 Overflow cup	(mm)	95	205	435

Stainless

Connection		A	B	C
XL1 Heating medium supply	(mm)	45	420	335
XL2 Heating medium return	(mm)	95	415	380
XL3 Cold water	(mm)	200	455	215
XL4 Hot water	(mm)	180	405	265
XL8 Docking	(mm)	220	290	300
WM1 Overflow cup	(mm)	95	205	435

Pipe dimensions

Connection		
XL1-XL2 Heating medium ext Ø	(mm)	22
XL3 Cold water ext Ø	(mm)	22
XL4 Hot water ext Ø	(mm)	22
XL5 Hot water circulation ext. Ø	(mm)	15
XL8 Docking ext. Ø	(mm)	22
WM2 Overflow water discharge	(mm)	32

Technical data

The following data only applies to F470 3x400 V. F470 is also available in voltage version 3x230 V. Contact your NIBE dealer for more information.

Type		Copper	Stainless
Output data according to EN 14 511			
Specified heating output (P_H) ¹	kW	2.18	
COP ¹		3.93	
Specified heating output (P_H) ²	kW	2.03	
COP ²		3.24	
Specified heating output (P_H) ³	kW	1.88	
COP ³		2.74	
Additional power			
Max power, immersion heater (factory setting)	kW	9.3 (4.6)	10.3 (5.6)
Energy rating, average climate			
Efficiency class room heating, average climate 35 / 55 °C		A+ / A+	
The system's efficiency class room heating, average climate 35 / 55 °C		A+ / A+	
Declared tap profile / efficiency class hot water heating		L / A	
Electrical data			
Rated voltage	V	400 V 3N ~ 50 Hz	
Enclosure class		IP 21	
Refrigerant circuit			
Type of refrigerant		R290, propane	
Volume	kg	0.44	
Heating medium circuit			
Opening pressure, safety valve	MPa/bar	0.25 / 2.5	
Max temperature, supply line (factory setting)	°C	70 (60)	
Ventilation			
Min. air flow at exhaust air temperature at least 20°C	l/s	28	
Min. air flow at exhaust air temperature below 20°C	l/s	31	
Noise			
Sound effect level according to EN 12 102 ($L_{W(A)}$) ⁴	dB(A)	51.5-54.5	
Sound pressure level in the boiler room ($L_{P(A)}$) ⁵	dB(A)	47.5-50.5	
Water heater and heating section			
Volume heating section	litre	70	
Volume, hot water heater	litre	170	
Max pressure in hot water heater	MPa/bar	1.0 / 10.0	
Capacity hot water heating			
Tap volume 40 °C according to EN 255-3(V_{max}) ^{6,7}	litre	248	
Tap volume 40 °C according to EN 16 147(V_{max}) ^{6,7}	litre	217	
Miscellaneous			
Required ceiling height	mm	2,270	
Weight	kg	212	204
Part No.		066 064	066 065

¹A20(12)W35, exhaust air flow 56 l/s (200 m³/h)

²A20(12)W45, exhaust air flow 42 l/s (150 m³/h)

³A20(12)W55, exhaust air flow 31 l/s (110 m³/h)

⁴The value varies with the selected fan curve. For more extensive sound data including sound to channels visit www.nibe.eu.

⁵ The value can vary with the room's damping capacity. These values apply at a damping of 4 dB.

⁶A20(12) exhaust air flow 42 l/s (150 m³/h)

⁷Comfort mode, normal

Accessories

Not all accessories are available on all markets.

Detailed information about the accessories and complete accessories list available at www.nibe.eu.

Docking kit DEH

There are separate docking kits available for connecting other heat sources to the heat pump.

Docking kit Solar 41

Solar 41 means that F470 together with e.g. NIBE UKVS 230 can be connected to thermal solar heating.

Extra shunt group ECS 40/ECS 41

This accessory is used when F470 is installed in houses with two or more different heating systems that require different supply temperatures.

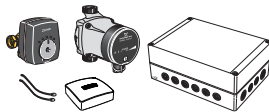

District heating module FJVM 220

Supplements F470 when connecting to district heating.

Communications module SMS 40

When there is no internet connection, you can use the accessory SMS 40 to control F470 via SMS.



Room unit RMU 40

RMU 40 means that control and monitoring of F470 can be carried out in a different part of your home to where it is located.



Solar package NIBE PV

Solar panel package with extremely long service-life to produce your own electricity.

3 kW	6 kW	9 kW
10 Solar panels	20 Solar panels	30 Solar panels
12 kW	21 kW	
40 Solar panels	70 Solar panels	

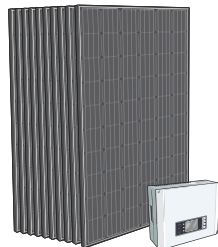

Water heater

For information regarding suitable water heaters, see www.nibe.eu.

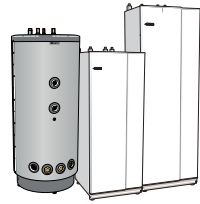

Top cabinet

Top cabinet that conceals the ventilation ducts.

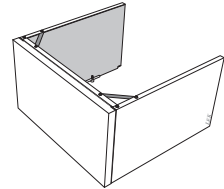

 **NIBE**