

User and Installer  
manual  
**VPB/VPBS**  
Water heater Accumulator tank



# Table of Contents

- 1 Important information** ..... **4**
- 2 For the User** ..... **6**
- 3 For the Installer** ..... **7**
- 4 Technical data** ..... **18**
- Contact information** ..... **23**

# 1 Important information

## Safety information

This manual describes installation and service procedures for implementation by specialists.

The manual must be left with the customer.

This appliance can be used by children aged from 8 years and above and persons with reduced physical, sensory or mental capabilities or lack of experience and knowledge if they have been given supervision or instruction concerning use of the appliance in a safe way and understand the hazards involved. Children shall not play with the appliance. Cleaning and user maintenance shall not be made by children without supervision.

Rights to make any design or technical modifications are reserved.

©NIBE 2017.

## Symbols



### NOTE

This symbol indicates danger to person or machine.



### Caution

This symbol indicates important information about what you should observe when maintaining your installation.



### TIP

This symbol indicates tips on how to facilitate using the product.

## Marking

**CE** The CE mark is obligatory for most products sold in the EU, regardless of where they are made.

## General

VPB/VPBS is designed and manufactured according to good technical practice<sup>1</sup> in order to ensure safe usage.

<sup>1</sup> Pressure Equipment Directive 2014/68/EU Article 4 point 3.

## Serial number

The serial number can be found at the bottom right of the front cover.



### Caution

Always give the product's serial number when reporting a fault.

## Recovery



Leave the disposal of the packaging to the installer who installed the product or to special waste stations.



Do not dispose of used products with normal household waste. It must be disposed of at a special waste station or dealer who provides this type of service.

Improper disposal of the product by the user results in administrative penalties in accordance with current legislation.

## Inspection of the installation

Current regulations require the heating installation to be inspected before it is commissioned. The inspection must be carried out by a suitably qualified person.

✓	Description	Notes	Signature	Date
	Heat pump (page 11)			
	Shut off valves			
	Hot water (page 11)			
	Shut off valves			
	Mixing valve			
	Cold water (page 11)			
	Shut off valves			
	Non-return valve			
	Safety valve			
	Electricity (page 16)			
	Sensors			
	Direct-current anode (only VPB/VPBS E)			

# 2 For the User

## Maintenance

### Safety valve (not supplied)

The water heater's safety valve sometimes releases a little water after hot water usage. This is because the cold water, which enters the water heater, expands when heated causing the pressure to rise and the safety valve to open.

The function of the safety valves must be regularly checked, about four times a year, to prevent clogging.

To inspect the valve, open the safety valve manually and check that water flows through the overflow pipe. If this does not happen then the safety valve is defective and must be replaced.

### Emptying

#### Water heater

Draining is performed through the siphon (using hose) in the cold water connection (XL3).

#### Charge coil

Draining is performed through the siphon (using hose) in the docking connection, return to heat pump (XL9).

#### Solar coil

Draining is performed through the siphon (using hose) in the connection, return to solar heating system (XL14).

## Service

For service, contact the installer. Serial number (PF3) (14 digits) and installation date should always be stated.

Only replacement parts supplied by NIBE may be used.

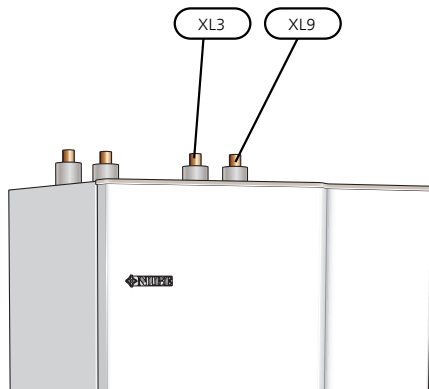

VPB 200/VPB 300

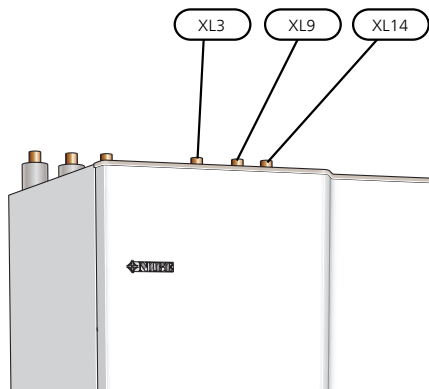

VPBS 300

# 3 For the Installer

## General

VPB/VPBS is a series water heater, which is suitable for connection to an external heat source.

The water tank has internal copper, stainless steel or enamel corrosion protection. The water heater is equipped with a charge coil that heats the domestic water, resulting in excellent properties for hot water charging.

VPBS 300 can be docked to thermal solar panels.

The water heater is designed and manufactured for a maximum cut-off pressure of 10 bar in the water heater and 3 bar on the primary side. Maximum permitted temperature is 85 °C.

VPBS 300 is equipped with a copper finned tube for connection of up to 6 m<sup>2</sup> of thermal solar panels.

The insulation is polyurethane, which provides excellent heat insulation. The outer shell of VPB/VPBS is powder-coated, white steel.

VPB/VPBS is equipped with a submerged tube for the sensors for external control and display of hot water heating.

VPBS 300 can be supplemented with a third sensor for solar control.

## Transport

VPB/VPBS should be transported and stored vertically in a dry place. The VPB/VPBS may, however, be carefully laid on its back when being moved into a building.

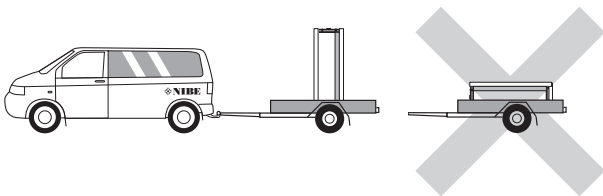

## Assembly

The water heater is only designed for upright installation.

The water heater's installation area should always have a temperature of at least 10 °C (frost-free).

Position VPB/VPBS on a firm base that can take the weight, preferably on a concrete floor or foundation. Use the product's adjustable feet to obtain a horizontal and stable set-up.

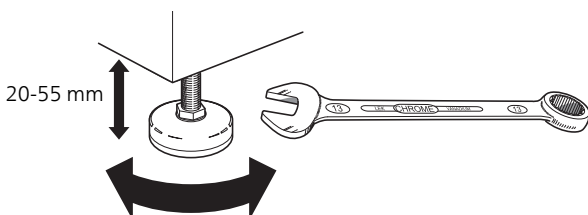

## Supplied components

### VPB/VPBS Enamel

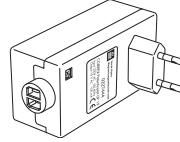

Potentiostat

# Component positions

VPB 200

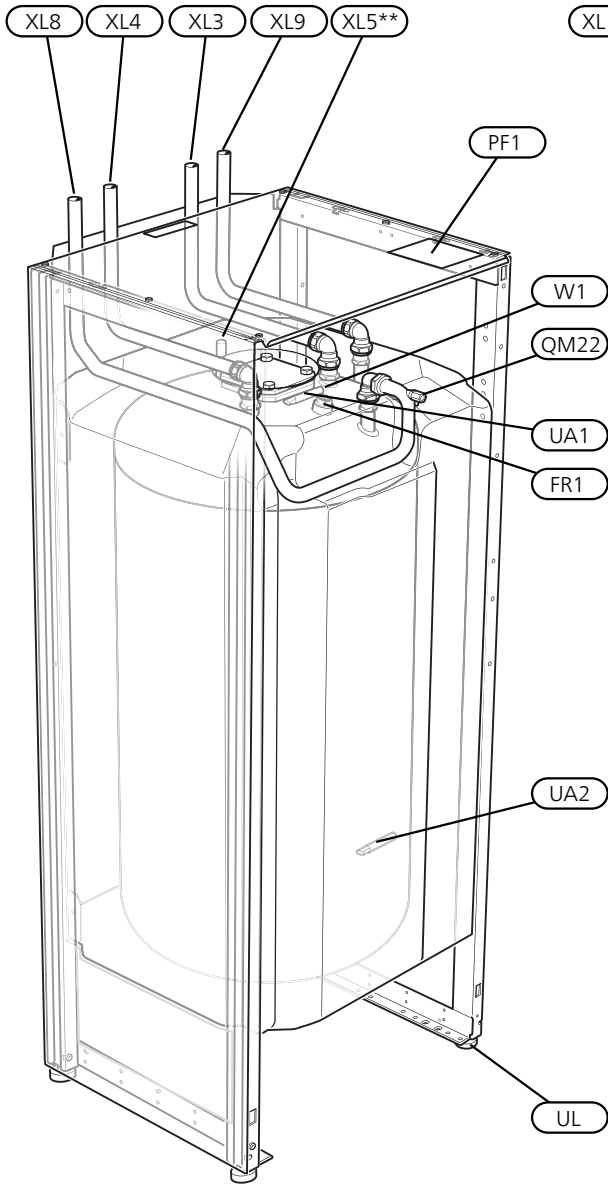

VPB 300 / VPBS 300

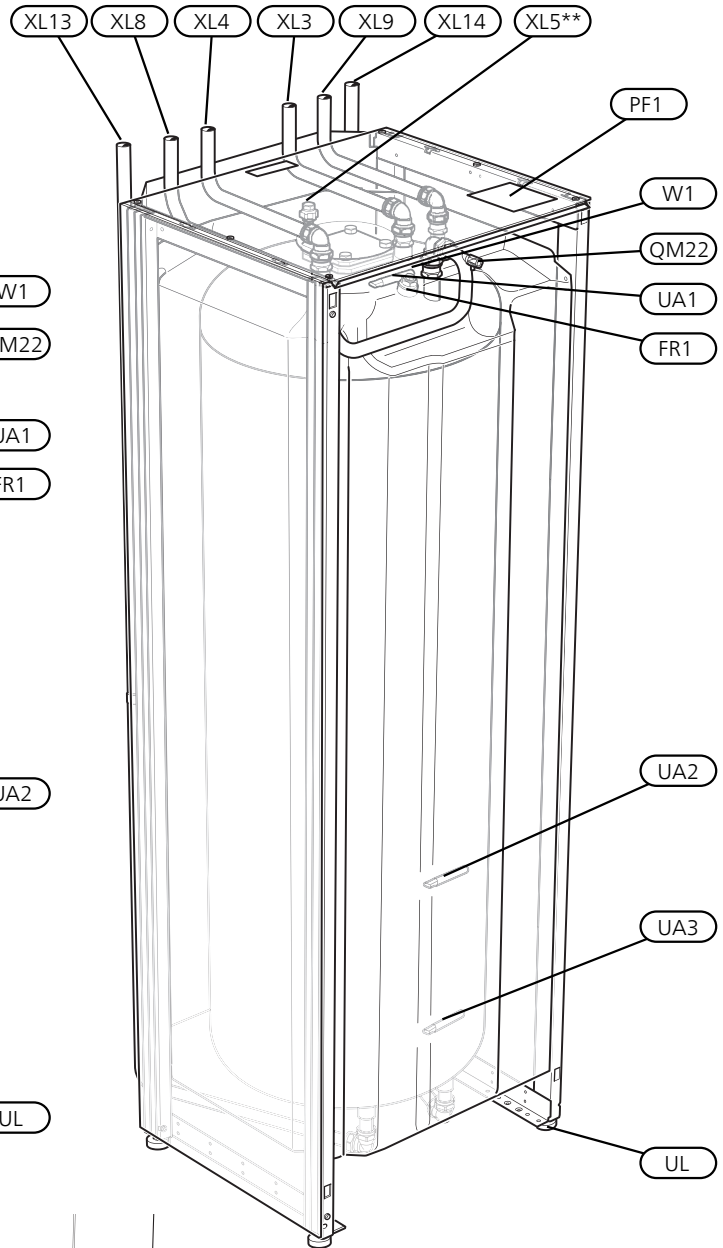

The figure shows VPBS 300

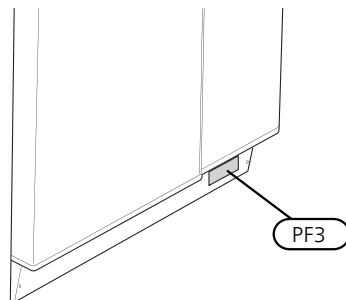

(\*\*Not VPB/VPBS Cu)



## Explanation

### **Pipe connections**

XL3	Connection, cold water
XL4	Connection, hot water
XL5	Connection, hot water circulation
XL8	Docking connection, supply line (from heat pump*)
XL9	Docking connection, return line (to heat pump*)
XL13	Connection, supply line (from solar heating system) (Only VPBS 300)
XL14	Connection, return line (to solar heating system) (Only VPBS 300)

### **HVAC components**

QM22	Venting, charge coil
UA1	Submerged tube for hot water sensor (display) BT7
UA2	Submerged tube for hot water sensor (control) BT6
UA3	Submerged tube for solar sensor (control)

### **Electrical components**

FR1	Direct-current anode (VPB/VPBS E)
W1	Cable to direct-current anode (VPB/VPBS E)

### **Miscellaneous**

PF1	Rating plate
PF3	Serial number plate
UL	Adjustable feet

Designations in component locations according to standard IEC 81346-1 and 81346-2.

\*or another external heat source

# Installation

## Removing the covers

### Front cover

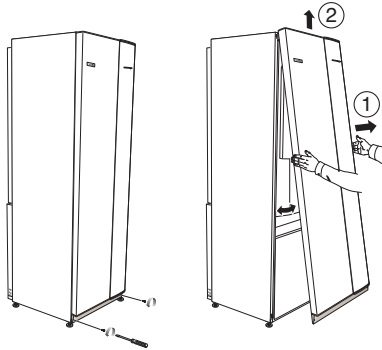

1. Remove the screws from the lower edge of the front cover.
2. Lift the cover out at the bottom edge and up.

### Side panels

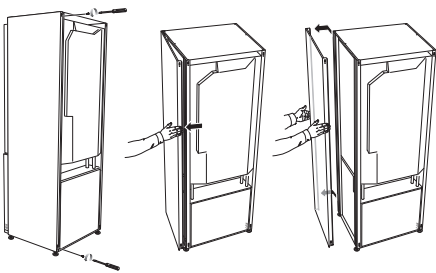

1. Remove the screws from the upper and lower edges.
2. Twist the cover slightly outward.
3. Move the hatch backwards and slightly to the side.
4. Pull the cover to one side.
5. Pull the hatch forwards.

## Pipe installation

Pipe installation must be carried out in accordance with current norms and directives.

The water heater must be fitted with the requisite valves, such as a safety valve, shut-off valve, non-return valve and vacuum valve.

The water heater must be provided with a mixer valve, which limits the temperature of outgoing hot water to 60 °C. If this valve is not fitted, some other measure must be taken to prevent the risk of scalding.

Internal support bushes must be fitted when a plastic or annealed copper pipe is used. An overflow pipe must be routed from the safety valve to a suitable drain. The overflow pipe must be the same size as the safety valve. Route the overflow pipe from the safety valve, sloping along its entire length and ensure that it is frost proof. The mouth of the overflow pipe must be visible and not placed close to electrical components.

### Pipe connections

VPB 200/VPB 300

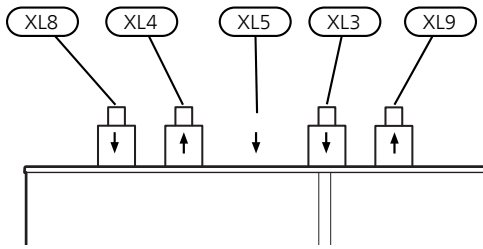

VPBS 300

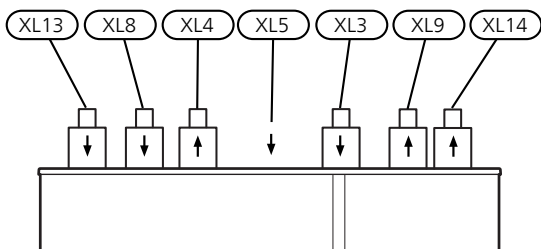

Connection		
XL3 Cold water Ø	mm	22
XL4 Hot water Ø	mm	22
XL5 Hot water circulation Ø (does not apply to VPB/VPBS -Cu)	mm	15
XL8 Docking connection, supply line Ø	mm	22
XL9 Docking connection, return line Ø	mm	22
XL13 Solar supply line Ø	mm	22
XL14 Solar return line Ø	mm	22

### Heat pump

The heat pump's supply and return are connected to XL8 and XL9 on VPB/VPBS.

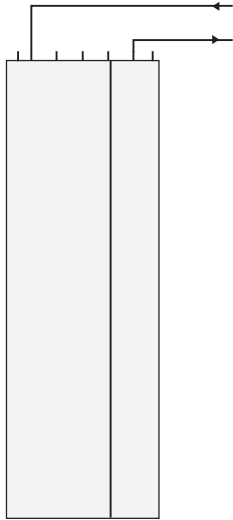

### Cold and hot water

Cold and hot water are connected to XL3 and XL4 on VPB/VPBS. There must be a mixer valve if the temperature can exceed 60°C.

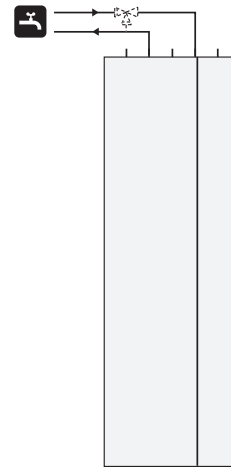

### Sun

The solar heating system's supply and return are connected to XL13 and XL14 on VPBS 300.

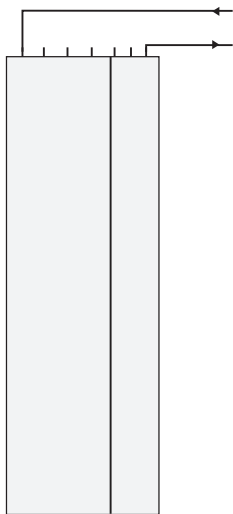

### Connecting hot water circulation

VPB/VPBS R and E have a connection that allows hot water circulation, and are connected to XL5 and XL4.

To reduce the risk of bacterial growth in systems with hot water circulation, the temperature of the circulating water should not fall below 50 °C. There should not be any non-circulatory hot water pipes either. Adjust the hot water system so that the temperature does not fall below 50 °C in the periphery of the system.

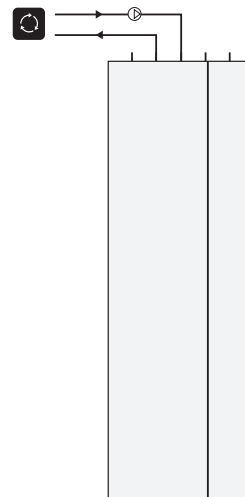

## Installation alternative

VPB/VPBS can be connected in several different ways, one of which is shown here.

Further option information is available at [nibe.eu](http://nibe.eu) and in the respective assembly instructions for the heat sources used.

### To ground heat

VPB/VPBS can be docked with another heat source, for example NIBE F1155.

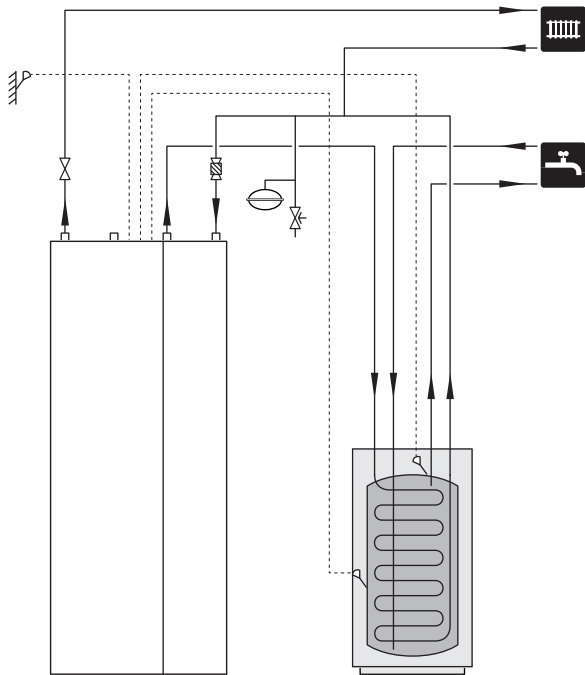

## Symbol key

Symbol	Meaning
	Venting valve
	Shut-off valve
	Mixing valve
	Safety valve
	Temperature sensor
	Expansion vessel
	Pressure gauge
	Circulation pump
	Particle filter

### To solar heating system

VPBS 300 can be docked to solar heating system.

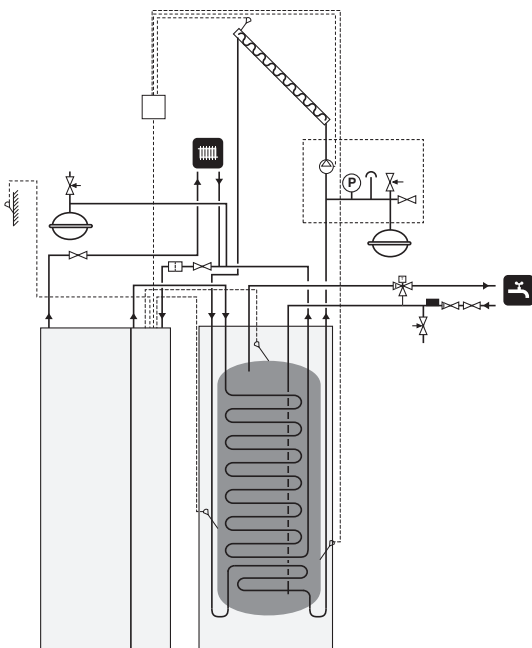

## Filling

### Filling and venting

#### *Filling the hot water heater*

1. Open a hot water tap in the house.
2. Fill the hot water heater through the cold water connection (XL3).
3. When the water that comes out of the hot water tap is no longer mixed with air, the water heater is full and the tap can be closed.

#### *Filling and venting the charge coil*

##### **Filling**

1. Open the filling valve (external, not included with the product). Fill the coil in the hot water heater and the rest of the climate system with water.
2. Open the vent valve (QM22).
3. When the water that exits the vent valve (QM22) is not mixed with air, close the valve. After a while the pressure starts to rise.
4. Close the filling valve when the correct pressure is obtained.

##### **Venting**

1. Vent the coil via the vent valve (QM22) and the rest of the climate system via the relevant vent valves.
2. Keep topping up and venting until all air has been removed and the pressure is correct.

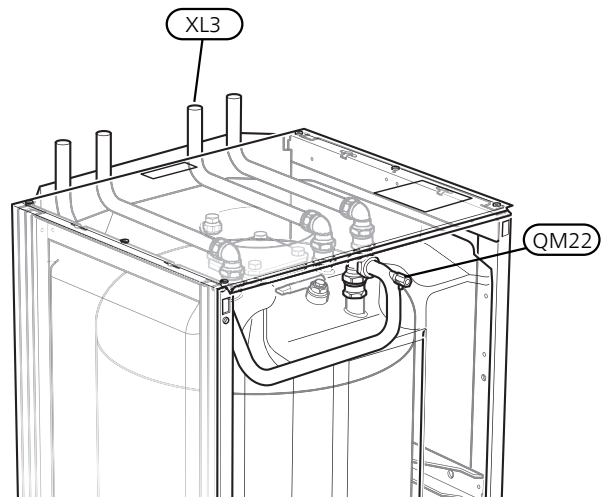

The figure shows VPB 200.

## Start-up and inspection

### Pressure drop diagram, charge coil

Docking connection, supply line (XL8) and docking connection, return line (XL9).

VPB 200

Pressure drop  
(kPa)

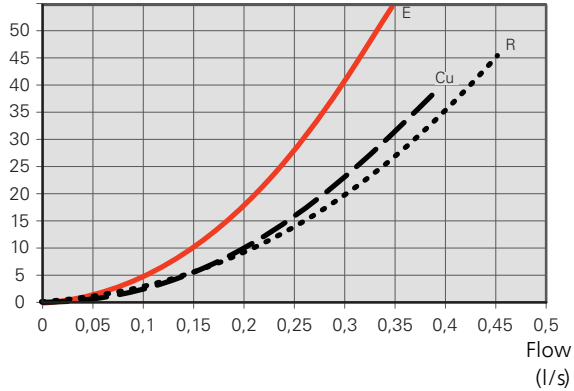

VPB 300 / VPBS 300

Pressure drop  
(kPa)

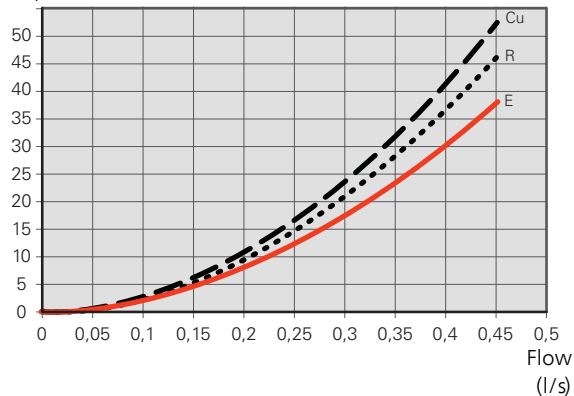

### Pressure drop diagram, solar coil

Connection, supply line solar heating system (XL13) and connection, return line solar heating system (XL14).

VPBS 300

Pressure drop  
(kPa)

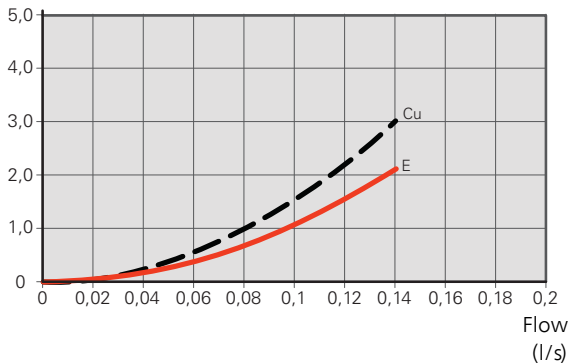

## Electrical installation



### NOTE

Electrical installation and service must be carried out under the supervision of a qualified electrician, and in accordance with applicable electrical safety regulations.

### Sensors

VPB 200 and VPB 300 can be supplemented with up to two hot water sensors, one for display and one for control. The display sensor is positioned in the submerged tube for the display sensor (UA1) and the control sensor UA2. In cases where it is only possible to connect one sensor, use the submerged tube for the control sensor (UA2).

VPBS 300 can also be supplemented with a solar sensor. This is placed in a submerged tube for the solar sensor (UA3).

Use the sensors provided with the heat pump (or other heat source). When no heat sensors have been provided these must be ordered from the manufacturer of the heat source.

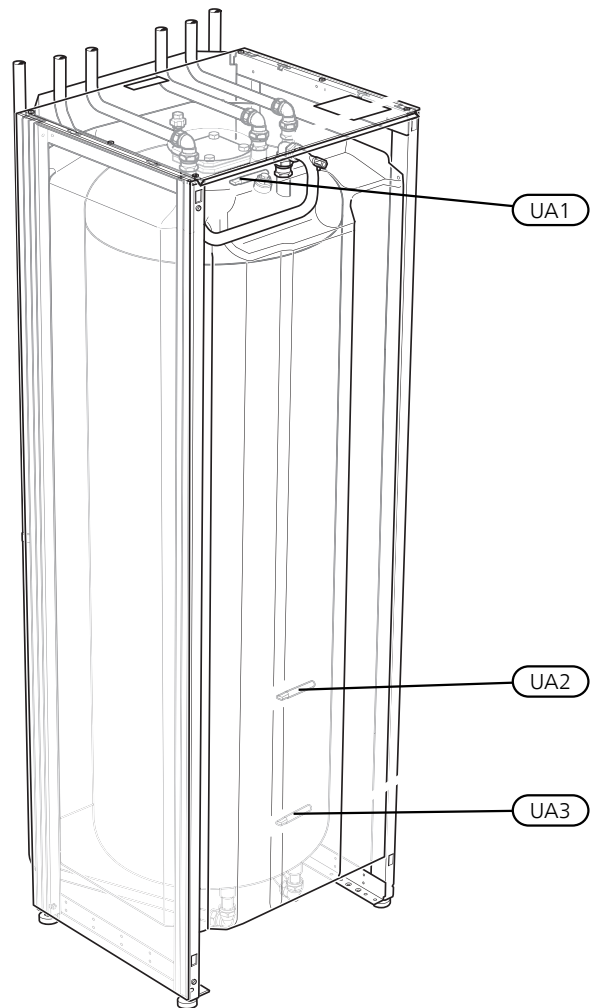

The figure shows VPBS 300.



## Direct-current anode

VPB/VPBS Enamel is equipped with direct-current anode and enclosed with potentiostat from the factory. The anode cable (W1) is installed in the anode from the factory and only needs to be connected to the potentiostat.

1. Route the anode cable (W1) along the docking pipe, supply line (XL8).
2. Connect the anode cable (W1) to the potentiostat.
3. Connect the potentiostat to a suitable 230 V wall socket.



### NOTE

The cable between the potentiostat and the anode must either be extended or shortened.

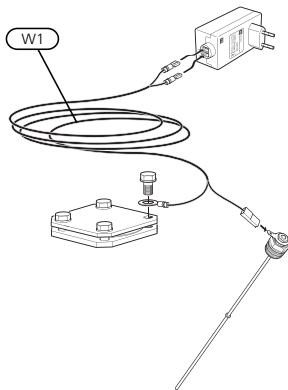
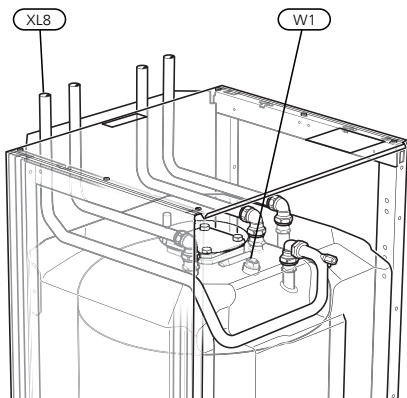

The figure shows VPB 200 E.

# 4 Technical data

## Dimensions

VPB 200

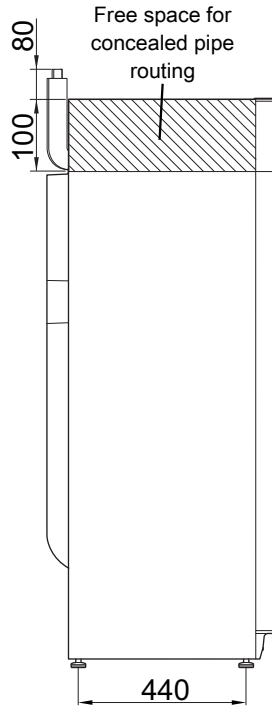
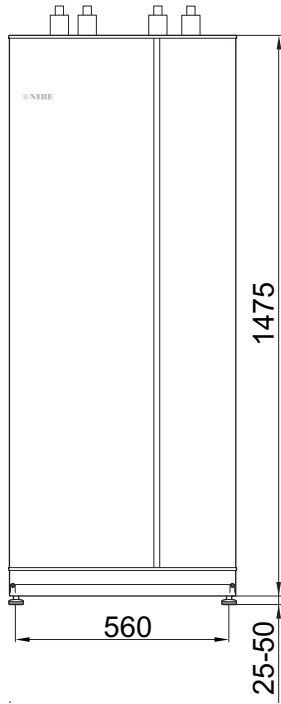

VPB 300/VPBS 300

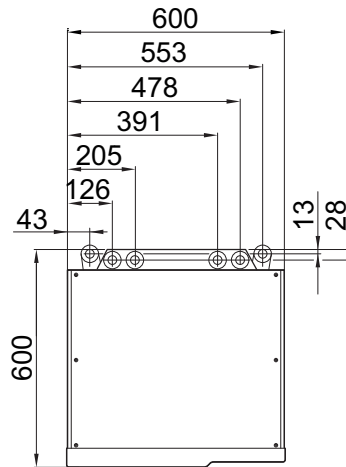
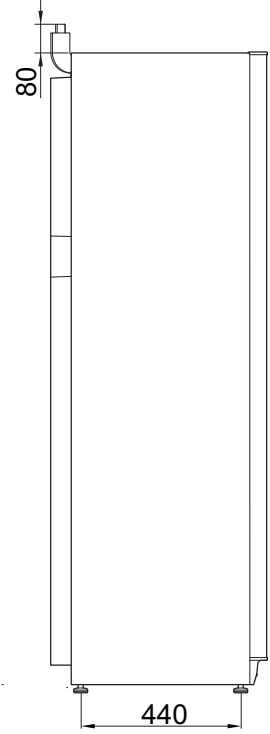
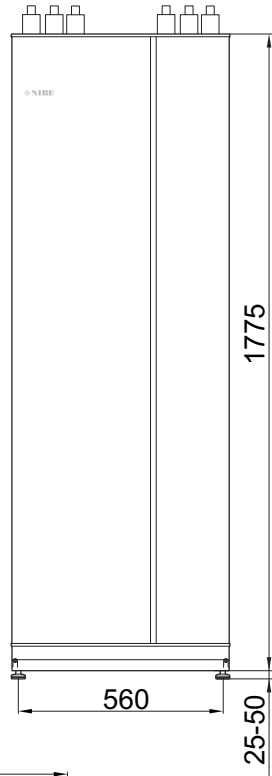

## Technical specifications

VPB 200		Copper	Enamel	Stainless
Efficiency class <sup>1</sup>		C	C	C
Volume	litre	178	178	176
Volume, charge coil	litre	2.0	4.8	7.8
Heat transfer (60/50°C at 50°C hot water temperature)	kW	13.0	10.1	10.1
Heat content at 50°C	kWh	8.0	8.3	8.2
Equivalent amount of hot water (40°C)	litre	230	238	235
Heating time (10°C to 45°C) 8 kW charge power	hours	0.9	0.9	0.9
Heating time (10°C to 80°C) 8 kW charge power	hours	1.8	1.8	1.8
Max operating temperature	°C	85		
Max pressure, primary side	bar/MPa	3/0.3		
Max pressure, water heater	bar/MPa	10/1.0		
Compatible NIBE heat pumps <sup>2</sup>	F1126-8,12, F1145-6,8,10,12, F2030-7,9, F2040-8,12,16, F1155-6,12,16, F2120-8,12,16			
Height	mm	1500		
Required ceiling height <sup>3</sup>	mm	1670		
Width	mm	600		
Depth	mm	600		
Net weight	kg	101	111	80
Part No.		081 068	081 069	081 070

<sup>1</sup>Scale for the product's efficiency class A+ - F.

<sup>2</sup>For ground source heat pumps, this recommendation applies to max. 10°C brine temperature and 53°C in the tank.

<sup>3</sup>With the feet removed, the required ceiling height is approx. 1650 mm.

VPB 300		Copper	Enamel	Stainless
Efficiency class <sup>1</sup>		C	C	C
Volume	litre	278	274	282
Volume, charge coil	litre	2	8.4	8.8
Heat transfer (60/50°C at 50°C hot water temperature)	kW	14	11.9	11.5
Heat content at 50°C	kWh	12.6	12.7	13.4
Equivalent amount of hot water (40°C)	litre	362	364	376
Heating time (10°C to 45°C) 8 kW charge power	hours	1.4	1.4	1.4
Heating time (10°C to 80°C) 8 kW charge power	hours	2.8	2.8	2.8
Max operating temperature	°C	85		
Max pressure, primary side	bar/MPa	3/0.3		
Max pressure, water heater	bar/MPa	10/1.0		
Compatible NIBE heat pumps <sup>2</sup>	F1126-8,12, F1145-6,8,10,12, F2030-7,9, F2040-8,12,16, F1155-6,12,16, F2120-8,12,16			
Height	mm	1800		
Required ceiling height <sup>3</sup>	mm	1950		
Width	mm	600		
Depth	mm	600		
Net weight	kg	130	143	101
Part No.		081 071	081 073	081 072

<sup>1</sup>Scale for the product's efficiency class A+ - F.

<sup>2</sup>For ground source heat pumps, this recommendation applies to max. 10°C brine temperature and 53°C in the tank.

<sup>3</sup>With the feet removed, the required ceiling height is approx. 1930 mm.

VPBS 300		Copper	Enamel
Efficiency class <sup>1</sup>	C	C	C
Volume	litre	277	270
Volume, charge coil	litre	2	8.4
Volume, solar coil	litre	0.8	4.0
Heat transfer (60/50°C at 50°C hot water temperature)	kW	14	11.9
Heat content at 50°C	kWh	12.4	12.4
Equivalent amount of hot water (40°C)	litre	354	356
Heating time (10°C to 45°C) 8 kW charge power	hours	1.4	1.4
Heating time (10°C to 80°C) 8 kW charge power	hours	2.7	2.7
Max operating temperature	°C	85	
Max pressure, primary side	bar/MPa	3/0.3	
Max pressure, water heater	bar/MPa	10/1.0	
Compatible NIBE heat pumps <sup>2</sup>	F1126-8,12, F1145-6,8,10,12, F2030-7,9, F2040-8,12,16, F1155-6,12,16, F2120-8,12,16		
Height	mm	1800	
Required ceiling height <sup>3</sup>	mm	1950	
Width	mm	600	
Depth	mm	600	
Net weight	kg	137	150
Part No.		081 078	081 079

<sup>1</sup>Scale for the product's efficiency class A+ - F.

<sup>2</sup>For ground source heat pumps, this recommendation applies to max. 10°C brine temperature and 53°C in the tank.

<sup>3</sup>With the feet removed, the required ceiling height is approx. 1930 mm.

Tested according to standard EN 12897.

## Energy labelling

Supplier		NIBE		
Model		VPB 200 Cu/E/R	VPB 300 Cu/E/R	VPBS 300 Cu/E
Energy efficiency class		<b>C</b>	<b>C</b>	<b>C</b>
Heat loss	W	66	88	95
Volume	l	178 / 178 / 176	278 / 274 / 282	277 / 270



# Contact information

- AT** **KNV Energietechnik GmbH**, Gahberggasse 11, AT-4861 Schörfling  
Tel: +43 (0)7662 8963 E-mail: mail@knv.at www.knv.at
- CH** **NIBE Wärmetechnik c/o ait Schweiz AG**, Industriepark, CH-6246 Altishofen  
Tel: +41 58 252 21 00 E-mail: info@nibe.ch www.nibe.ch
- CZ** **Druzstevni zavody Drazice s.r.o.**, Drazice 69, CZ - 294 71 Benátky nad Jizerou  
Tel: +420 326 373 801 E-mail: nibe@nibe.cz www.nibe.cz
- DE** **NIBE Systemtechnik GmbH**, Am Reiherpfahl 3, 29223 Celle  
Tel: +49 (0)5141 7546-0 E-mail: info@nibe.de www.nibe.de
- DK** **Vølund Varmeteknik A/S**, Member of the Nibe Group, Brogårdsvej 7, 6920 Videbæk  
Tel: +45 97 17 20 33 E-mail: info@volundvt.dk www.volundvt.dk
- FI** **NIBE Energy Systems OY**, Juurakkotie 3, 01510 Vantaa  
Tel: +358 (0)9-274 6970 E-mail: info@nibe.fi www.nibe.fi
- FR** **NIBE Energy Systems France Sarl**, Zone industrielle RD 28, Rue du Pou du Ciel, 01600 Reyrieux  
Tel : 04 74 00 92 92 E-mail: info@nibe.fr www.nibe.fr
- GB** **NIBE Energy Systems Ltd**, 3C Broom Business Park, Bridge Way, S419QG Chesterfield  
Tel: +44 (0)845 095 1200 E-mail: info@nibe.co.uk www.nibe.co.uk
- NL** **NIBE Energietechniek B.V.**, Postbus 634, NL 4900 AP Oosterhout  
Tel: 0168 477722 E-mail: info@nibenl.nl www.nibenl.nl
- NO** **ABK AS**, Brobekkveien 80, 0582 Oslo, Postadresse: Postboks 64 Vollebekk, 0516 Oslo  
Tel: +47 23 17 05 20 E-mail: post@abkklima.no www.nibe.no
- PL** **NIBE-BIAWAR Sp. z o. o.** Aleja Jana Pawła II 57, 15-703 BIALYSTOK  
Tel: +48 (0)85 662 84 90 E-mail: sekretariat@biawar.com.pl www.biawar.com.pl
- RU** © "EVAN" 17, per. Boynovskiy, RU-603024 Nizhny Novgorod  
Tel: +7 831 419 57 06 E-mail: kuzmin@evan.ru www.nibe-evan.ru
- SE** **NIBE AB Sweden**, Box 14, Hannabadsvägen 5, SE-285 21 Markaryd  
Tel: +46 (0)433 73 000 E-mail: info@nibe.se www.nibe.se

For countries not mention in this list, please contact Nibe Sweden or check [www.nibe.eu](http://www.nibe.eu) for more information.

NIBE AB Sweden  
Hannabadsvägen 5  
Box 14  
SE-285 21 Markaryd  
info@nibe.se  
www.nibe.eu



431320