

English
Version 08.01.2014

INSTALLATIONS MANUAL



NIBE

GV-HR110

Passive ventilation / Heat recovery

Table of Contents

| | |
|--|----|
| GV-HR110 - assembly | 4 |
| Duct connection | 6 |
| Condensation drain | 6 |
| Duct system | 7 |
| Insulating ducts in cold attics | 7 |
| Insulating ducts in warm rooms | 8 |
| Post-heating of incoming air | 8 |
| Electric installations | 9 |
| Control and settings of the facility | 9 |
| Optimal adjustment of the facility | 9 |
| Facility maintenance | 10 |
| Troubleshooting | 12 |
| Electric wiring diagram | 13 |
| CE-conformity marking | 15 |

■ **IMPORTANT** ■ **IMPORTANT** ■ **IMPORTANT** ■ **IMPORTANT** ■

To assemble GV-HR110 follow the instructions below:

- 1) Remember to switch off the electricity before opening the aggregate.
- 2) An airtight waterseal must be mounted in a frost-free place to compensate for the pressure from the ventilation unit.
- 3) The height of the waterseal must be at least 50 mm.
- 4) The pipe drain must fall freely to the sewer drain.
- 5) Pour 1 litre water into the condensation container of the machine to check that the water flows without stoppage. The waterseal must be checked for water every year before the cold season begins.
- 6) If the waterseal is mounted where the temperature can fall below 0 C°, then the waterseal must be protected against frost with a thermostat and an electric heating element that switches on when the temperature falls below +2 C°.
- 7) Set the amount of incoming 1 - and outgoing air before using the facility. It is very important that the air balance in the house is correct.
- 8) It is recommended to close the air valves etc. until the machine has been started up and the settings made.

Follow the instruction in this manual. If the drain is not set up in accordance with the manual, NIBE will not be liable for any consequential damages pertaining to the NIBE facility.

■ **IMPORTANT** ■ **IMPORTANT** ■ **IMPORTANT** ■ **IMPORTANT** ■



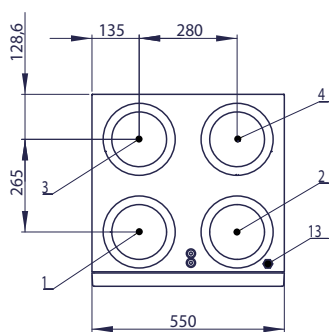
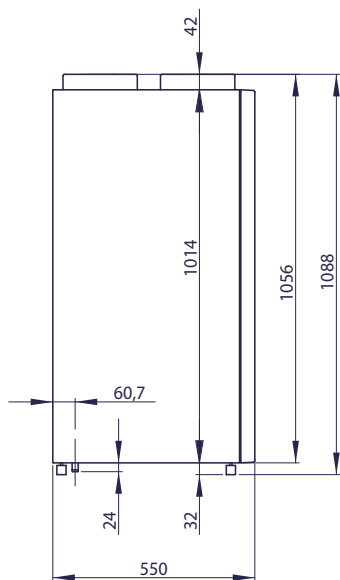
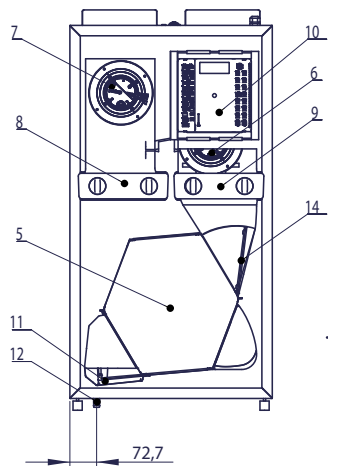

- | | |
|--------------------------------|----------------------------|
| 1: Fresh air | 8: Supply air filter |
| 2: Extract air | 9: Extract air filter |
| 3: Exhaust air | 10: Electric control box |
| 4: Supply air | 11: Condensation container |
| 5: Counter-flow heat exchanger | 12: Condensation drain |
| 6: Supply air fan | 13: 230V/50Hz |
| 7: Extract air fan | 14: Bypass |

GV-HR110 - Assembly

GV-HR110 is delivered upright or as horizontal.

The aggregate must be assembled on a vibrationfree, firm substrate (cement, brick, etc.) or onto a solid wall. Since the aggregate can produce up to 6 litres of water per day during the winter months it must be placed where the necessary waterseal and its condensation drain-off can be lead off to in a satisfactory way to the indoor drain.

In order to be able to service and maintain the aggregate there must be at least 600 mm of space in front of the aggregate and it must stand on a firm substrate.

Weight: 32 kg

Concealed wall mountings

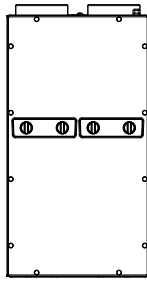
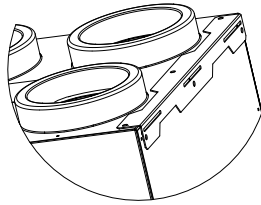

Visible wall mountings

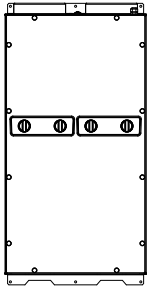
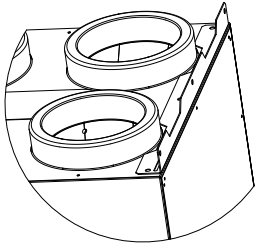

Cabinet assembly



Horizontal mounting

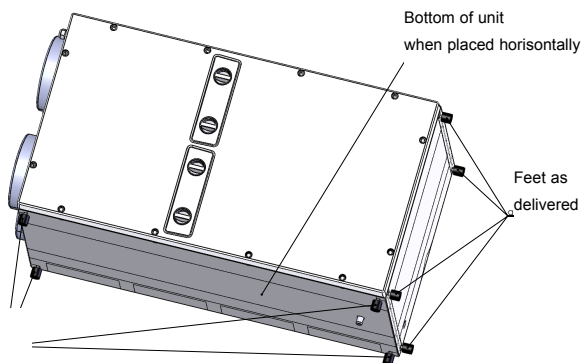

When mounted horizontally, place feet as shown

Assembly

GV-HR110 is delivered with universal wall mountings consisting of 2 rails.

Wall assembly

GV-HR110 can also be mounted directly on the wall with visible or concealed wall mountings.

Cabinet assembly

GV-HR110 is made for mounting in a normal 60 x 60 cm cabinet, as shown in the drawing. When assembling a cabinet the aggregate can be placed on the wall mounting delivered with the aggregate (as shown in the picture).

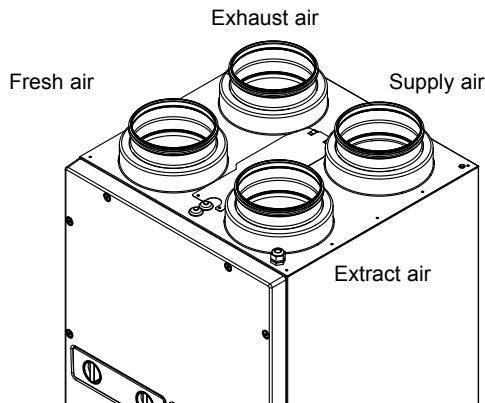

GV-HR110

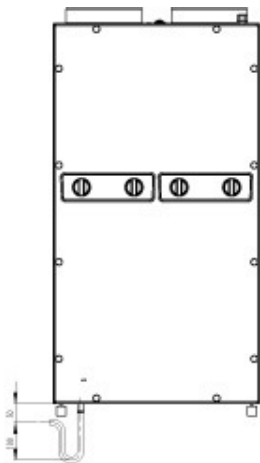

No water in the waterseal = water damages

Duct connection

All duct connections have yellow markings that indicate which ventilation ducts are connected to the different connections.

Incoming air connection: 
The duct system from the aggregate to the residence.

Outgoing air connection: 
The duct system from the residence to the aggregate.

Outside air connection: 
The duct system from the outside air hood/outside air grid or from the ground heat exchanger to the aggregate.

Exhaust air connection: 
The duct systems from the aggregate to the exhaust air hood/exhaust air grid outdoors.



Optimal operation of the GV-HR110 is achieved by mounting a connector piece $\varnothing 160$ mm in each of the four outlets as the first step of the duct system. The connectors are tightened with the supplied collar bands.

Condensation drain

The aggregate produces up to 6 litres condensation per day. It is therefore important that the condensation drain is set up correctly and that the aggregate declines toward the condensation drain side.

The waterseal must be airtight e.g. by bending a 15 mm copper pipe as a waterseal (see the drawing on the left). A reinforced water hose is attached between the drain connection and the waterseal using a hose clip on both connections.

A necessary decline of 1 % is installed from the waterseal to the inside drain. If the aggregate is mounted in a cold air room then the condensation drain pipe must be insulated so that the condensation inside the pipe does not freeze. We also recommend that the waterseal is mounted in an underlying warm room to guarantee that the water in the waterseal does not freeze.

If protection of the condensation drain pipe against frost cannot be guaranteed when installing then a thermostat-controlled heating strip must be assembled around the condensation drain pipe. When hanging on wood walls we recommend using a vibration-dampener to avoid transferring vibrations.



During operation there is negative pressure in the aggregate, which makes it necessary to guarantee a height difference of at least 50 mm down to the water in the waterseal.



Duct system

We recommend that the duct system be made of spiralflanged pipes and couplings made with rubber ring seals to assure a sealed, durable duct system.

To assure a satisfactory low aggregate noise level, always mount an exhaust silencer on the ingoing and outgoing duct system between the aggregate and the first ingoing and outgoing units.

We recommend dimensioning the air speeds in the ducts sufficiently low so that no noise occurs from the ingoing and outgoing air units.

When placing the outgoing air and exhaust hood/grid make sure that the two air flows are not short-circuited thereby avoiding the outgoing air being sucked in again.

We recommend placing a grid on the north or east side of the house for optimal comfort in the residences/flats.

Minimum distance: 3 metres between the outside air intake and exhaust air.

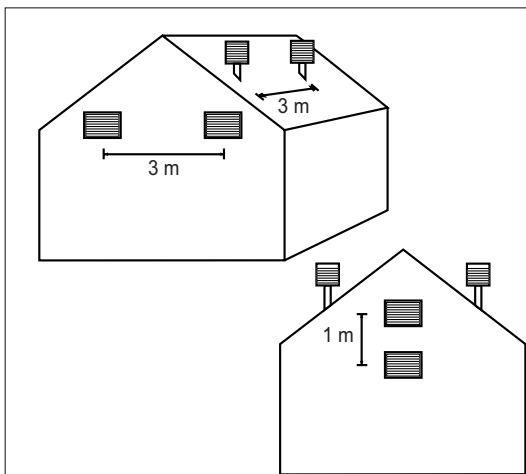

Insulating ducts in cold rooms

If you want to make use of the aggregate's high recycling rate (efficacy), the ducts must be insulated correctly.

Incoming and outgoing air ducts:

To reduce heat loss from the duct system in cold attics the ingoing and outgoing air ducts must be insulated with at least 100 mm insulation. If the insulation alternative A is used, we recommend the insulating be done with 2 times 50 mm plate covers with paper or aluminium foil on the outside and overlaying joints between the 2 insulation layers. If the ducts are laid out on the roof rafters, then alternative B can be used. The insulation must always be packed tightly around the pipes.

Outside air and exhaust air ducts in cold rooms:

Outside air and exhaust air ducts must be insulated with PE30-insulation. The outside air ducts can be insulated with even thicker insulation to avoid warm air in the attic from heating the incoming air during the summer.

Make sure that the closures are tight where the exhaust air duct comes through the roof or through the gable so that damage from condensation is avoided.

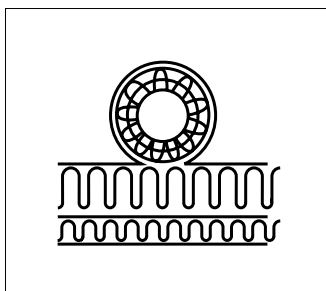

Insulation of ducts alt. A

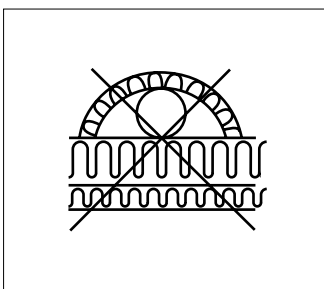

Incorrect insulation of ducts

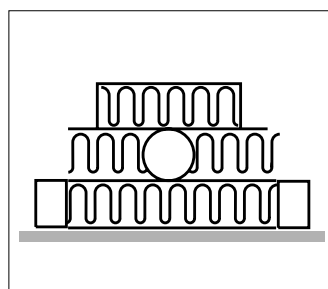

Insulation of ducts, alt. B

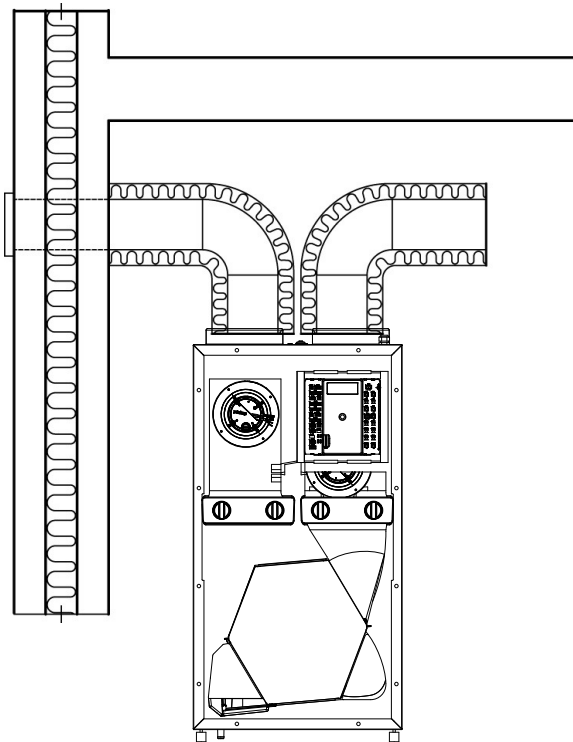

Insulation of ducts in warm rooms

Incoming and outgoing air ducts:

In hot attic rooms the incoming and exhaust air ducts must be insulated with 50 mm insulation with aluminium foil outermost.

Outdoor and exhaust ducts that lead up into heated rooms in the residence do not need to be insulated unless they are used for cooling, bypass or ground heat exchangers. In that case, the incoming air pipe must be insulated.

Outside and exhaust ducts:

In a hot attic room and heated residence room the outside and exhaust air ducts must be insulated with PE30 insulation. Also, the insulation must be clad on the outside with plastic or aluminium foil to avoid condensation in the insulation.

When using any heat exchangers we recommend 100 mm insulation on the outside air duct.

Postheating incoming air

Since the counter-flow heat exchanger cannot recycle all heat from the exhaust air to the incoming air, the incoming air will be approx. 1-4 °C lower than the room temperature of the residence during the winter season. If you want to use the facility for heating, you can mount a water-based or electric postheater that can heat the incoming air to room temperature.

Water based postheater:

To protect the water based postheater from frost damages, it must be equipped with a frost sensor and it must be insulated. The frost sensor is mounted behind the plates of the water-based postheater. The sensor that controls the motor valve is mounted in the incoming air duct approx. 500 mm behind the water-based postheater, so that it will not be affected by the radiant heat from the heating element. The water connection to the water based postheater must be performed by an authorised sanitary and heating installer.

Electric postheater:

The control sensor for the electric postheater is mounted in the incoming air duct approx. 500 mm behind the electric postheater, so that it will not be affected by the radiant heat from the heating element.

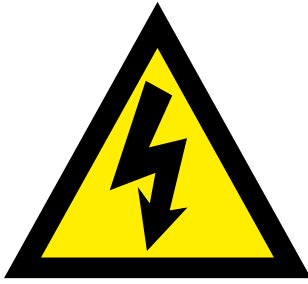

Electric installations

The electric installations must be performed by an authorised electrician. See the electric wiring diagram included. The cable between the aggregate and control panel is a 4-lead cable, max. 50m.

Control and settings of the facility

For optimal operation of the facility it must be set using technical ventilation measurement instruments.

To use the facility before installing, do the following:

Before using the facility:

- 1: Check that the NIBE-aggregate is correctly mounted and that all the ducts are insulated according to instructions.
- 2: Check that the lid can be opened so that service and maintenance of the aggregate can be performed.
- 3: Check that the filter is clean (may be dirty after assembly)
- 4: Check that the condensation drain is correctly mounted with a waterseal and that it is protected from frost. Pour 1 litre of water into the condensation container and check that it flows unimpeded through the condensation drain pipe.
- 5: Set all incoming air units so that the unit closest to the aggregate will open 3 turns from the locked position while the outermost will open 8 turns from the locked position. The unit in-between will open between 4-7 turns, depending on how close to the aggregate they are.
- 6: If a postheater is assembled (not sold by NIBE) on the facility set the incoming air temperature to 0-3 °C below the room temperature of the residence.

The facility can now be used and run until the facility is adjusted using technical ventilation measurement instruments.

Optimal adjustment of the facility

Calibrated technical ventilation equipment must be used to adjust a NIBE-ventilation facility for residences. Before adjusting, check that the 6 items in the section on control and settings have been performed. The facility can then be used.

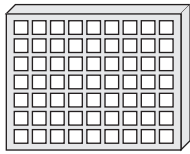

G4 = Standard filter (Coarse filter class G4)
 F7 = Pollen filter (Fine filter class F7)

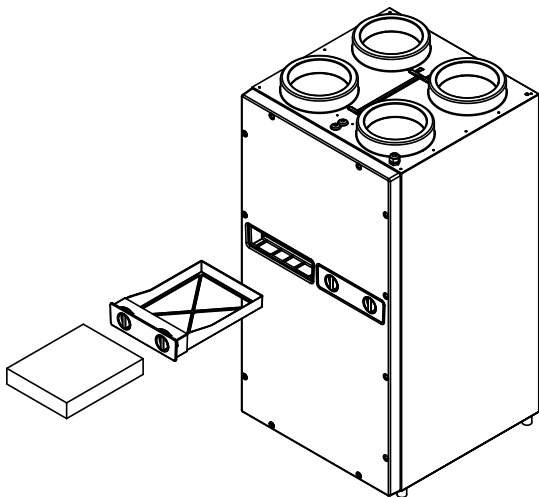

Closed filter unit

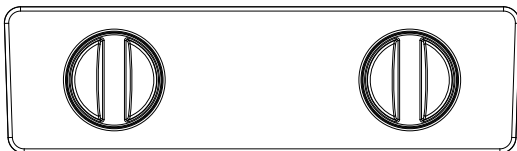

Open filter unit



Facility maintenance



Remember to switch off the power supply before opening the aggregate.

Filter:

When the red light flashes on the control panel the filter must be changed/cleaned.

The facility is turned off with the facility switch or with the switch by the fuse cabinet. It is not necessary to remove the lid to exchange the filter. The filter unit can only be opened by turning both knobs one quarter turn counter-clockwise (to the left). The filter unit is pushed into place by reversing the procedure; both knobs must be turned one quarter turn clockwise (to the right).

When the filter has been exchanged or cleaned by shaking them to remove most of the dirt, the filter timer is set by pressing "Enter" for 10 to 15 seconds until the NIBE-logotype flashes once again and the facility is back to normal operation.

If you want to clean the filter at another time interval, this can be adjusted in item 14 of the Operations menu, The incoming air filter (F7) on the left side is higher up than the outgoing filter (G4).



Do not use a vacuum cleaner or air pressure on the filter as this deteriorates the filtration effect.

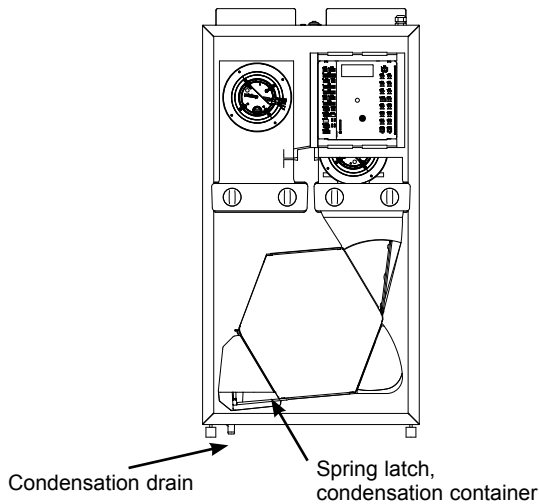

Counter-flow heat exchanger

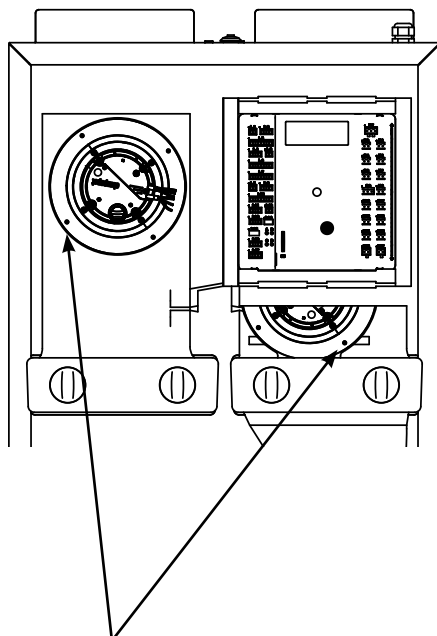
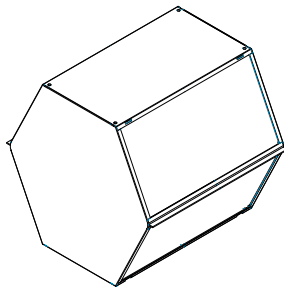

The four outermost screws that hold the fans in place must be removed in order to remove the fans.

Condensation drain:

When it is time to exchange the filter in the fall, check the condensation drain for fouling by dirt and make sure there is water in the waterseal. The waterseal must not dry out since the negative pressure of the aggregate will suck air into the aggregate causing the condensation to remain in the aggregate. Pour 1 litre of water into the condensation container and check that the flow is undeterred. If the condensation drain does not work correctly water damages may occur in the residence.

Counter-flow heat exchanger

The counter-flow heat exchanger must be overseen every year. Remove it if it is dirty and vacuum it without touching the plates. Open the front of the condensation container before removing the counter-flow heat exchanger. This is done by opening the spring latch on the right corner of the condensation container. Push lightly from behind when removing the counter-flow heat exchanger.

 **Do not damage the plates. The effect will no longer be optimal if the plates are damaged.**

Fans:

Remember to switch of the power supply!!

Check the fans in the fan wheel for dirt every third year. The four outermost screws that hold the fans in place must be removed in order to remove the fans. Remove the front lid of the unit. Clean the fans using a brush, fan brush or paintbrush.

 **The filter units must be removed before disassembling the front lid.**

Incoming and outgoing units:

The ventilation unit must be cleaned regularly with a small brush in order to maintain correct ventilation. Do not change the setting. N.B. Do not mix the units up when many are cleaned at the same time.

Troubleshooting

Turn off the facility

No lamps are lit on the service panel, even when you press on both buttons.

Error:

- A fuse has blown in the fuse box, no power supply to the facility.
- One of the fuses on the circuit board has shorted.
- Loose contact, no voltage to the aggregate.
- Loose contact between the aggregate and control panel.

Red light constantly lit on the control panel:

Error for control:

- Frost thermostat switched off. (Facilities with water heaters.)
- Faulty sensor in aggregate
- Faulty sensor in control panel
- If no sensor is attached for incoming air it has been replaced by a resistor that is faulty
- Loose sensor wire or loose bridge in coupling list on the circuit board.

Condensation flowing from the aggregate:

Error:

- Condensation drain fouled with dirt
- No water in the waterseal
- Condensation drain fouled due to frost.
- Drain is not sufficiently protected from frost

No incoming air to the residence:

Error:

- Faulty fan
- Fouled incoming air filter
- Fouled outside air grid
- A fuse has blown on the circuit board
- No power supply to the facility

No exhaust air from the residence:

Error:

- Faulty fan
- Fouled filter
- A fuse has blown on the circuit board

Cold incoming air

Error:

- Counter-flow heat exchanger is fouled with dirt or ice.
- Faulty exhaust fan
- Fouled exhaust air filter
- An electric postheater is disconnected due to overheating protection (Only facilities with electric postheaters mounted).
- No circulation of hot water to the waterborne postheater. (Only facilities with mounted waterborne postheaters).
- Fouled circulation pump, air in the hot water pipe, faulty thermostat/motor valve, faulty setting of control panel.

Display message:

Computer error:

- no connection with circuit board
- lead too long between display and circuit card

Version error:

- Program displayed and circuit card not compatible

Exchange filter:

- Filter must be changed

Stop ON-OFF:

- Filter has not been exchanged/cleaned within 14 days from the filter alarm being triggered.
The facility is turned off.

Electric wiring diagram GV-HR110

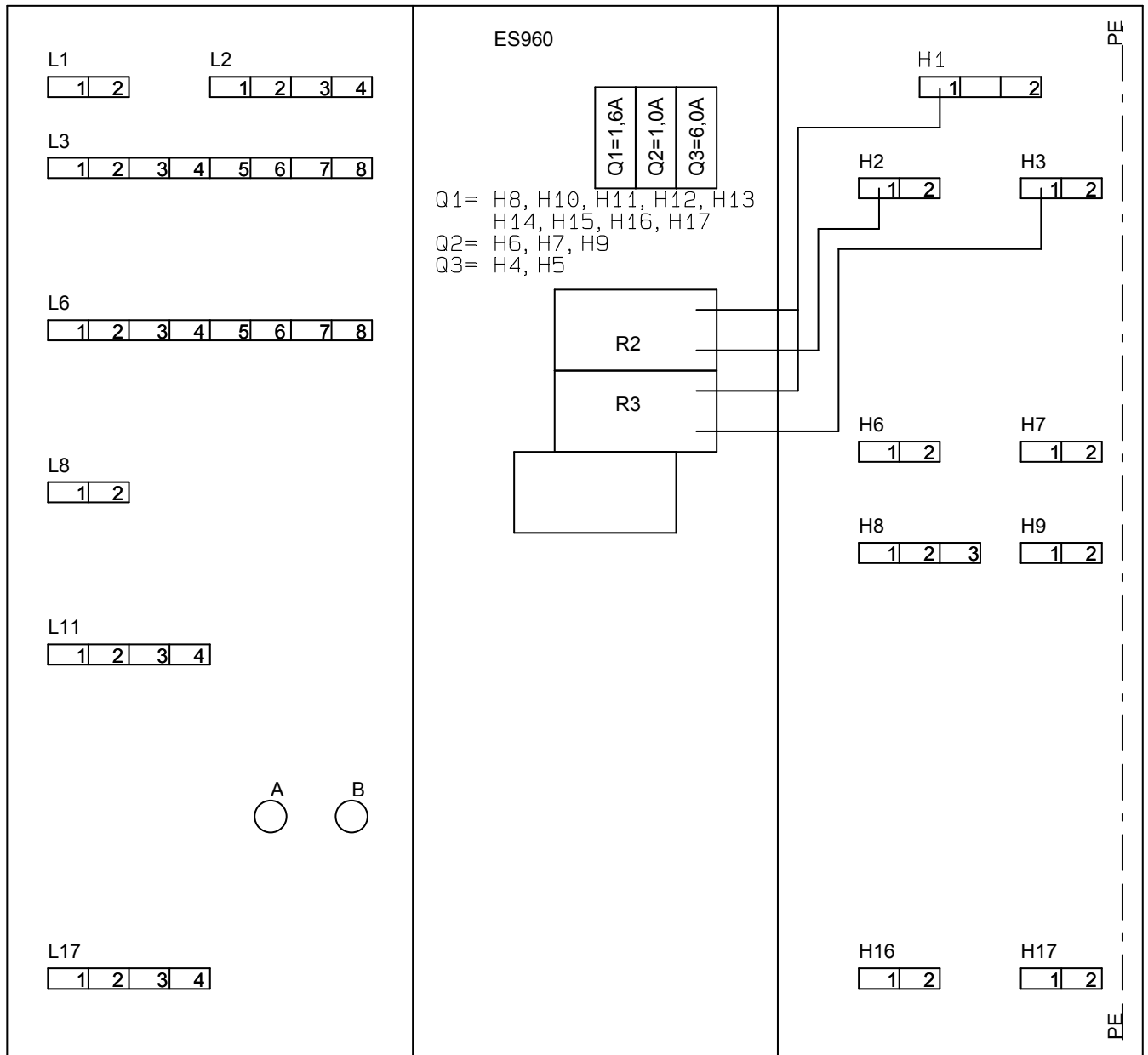

Electric wiring diagram GV-HR110

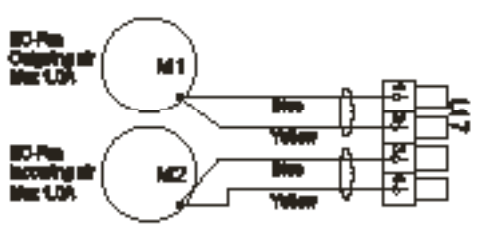
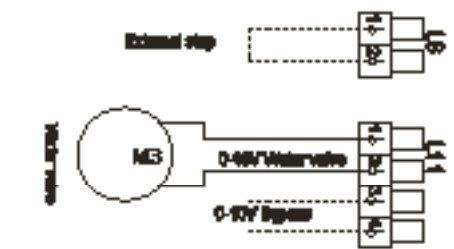
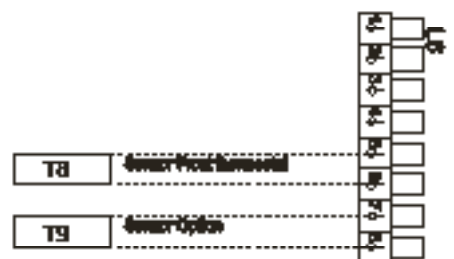
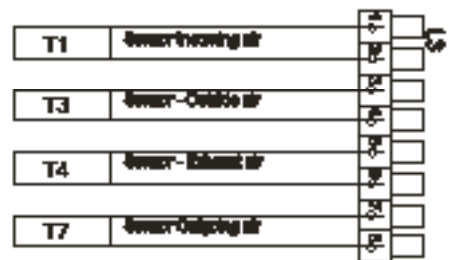
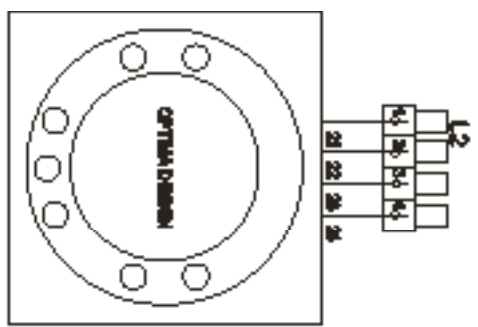
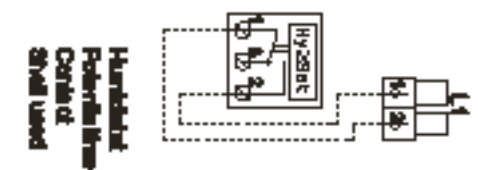
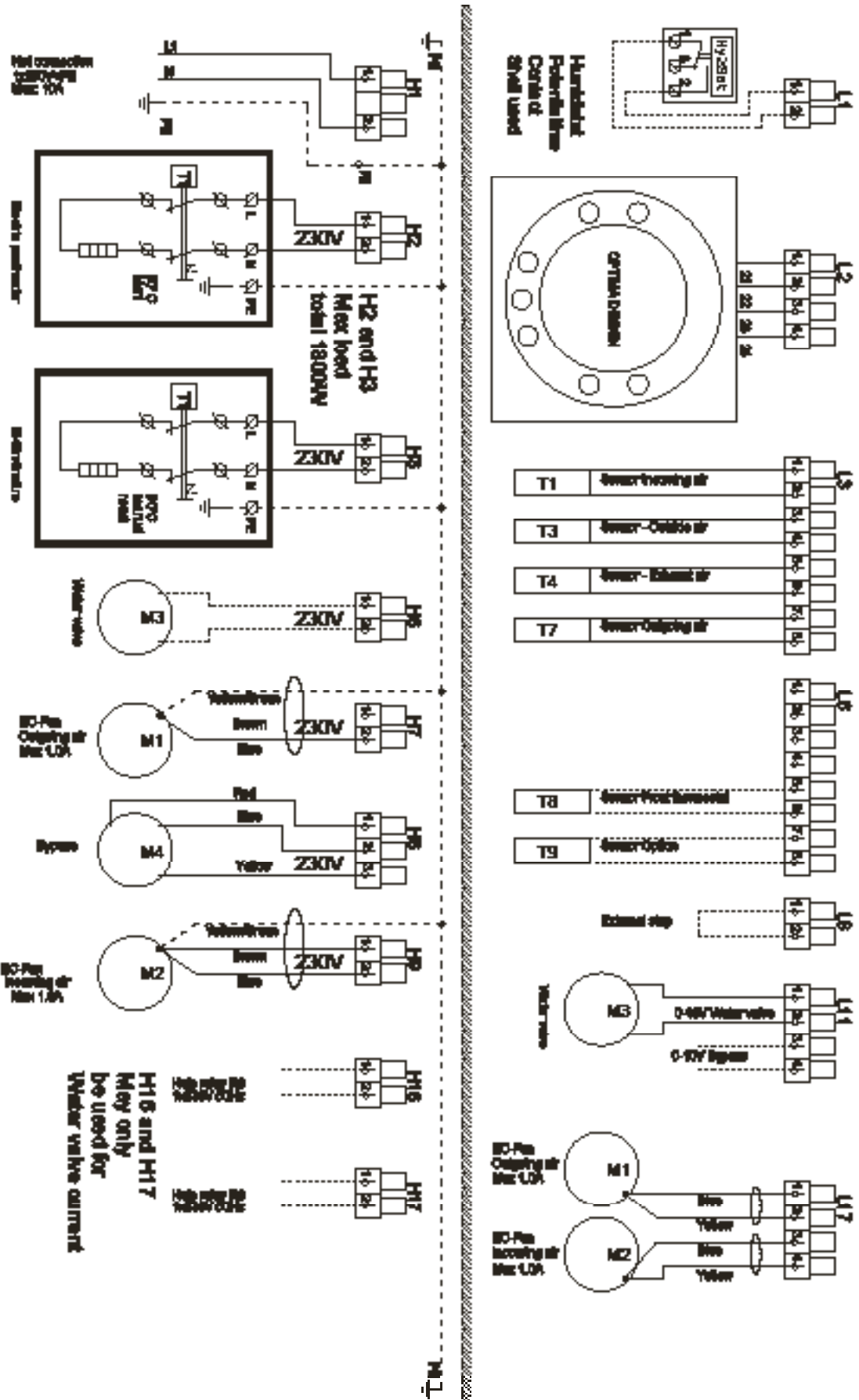

H16 and H17
May only
be used for
Water valve current

CE-Manufacturing Assurance GV-HR110



EF - Försäkran om Överensstämelse
EC - Declaration of Conformity
EG - Konformitätserklärung



Intyggar härmed att följande produkt / hereby certifies that the following product / beståttigt, da das nachfolgend bezeichnete Gerät:

- B. Beteckning : **Nibe™ GV-HR110-250**
Type : **Nibe™ GV-HR110-250H**
Typ: : **Nibe™ GV-HR110-400**
 : **Nibe™ GV-HR110-400H**
- C. Huvednr : 066033, 066039, 066046, 066047, 912001, 912002
S/N :

Under förutsättning att Nibe Energy Systems monteringsanvisningar har följts / on the assumption that the mounting instructions from Nibe energy Systems have been followed / bei Voraussetzung dass die Montageanweisungen von Nibe Energy Systems gefolgt wurden

Har tillverkats i överensstämmelse med / is made according to / über Einstimmung von nachfolgend bezeichnete EG-Sicherheitsstandards hergestellt:

Directive:



- | | |
|----------------------------------|-------------------------------|
| a) Machinery | 2006/42/EC 15. March 2006 |
| b) Low Voltage | 2006/95/EU 12. December 2006 |
| c) Electromagnetic Compatibility | 2004/108/EC 15. December 2004 |
| d) Radio/Telecommunication | 99/5/EC 9. March 1999 |
| e) RoHS | 2011/65/EU 8. June 2011 |

Departmental Order.

- a) No. 797 17. August 2009
- b) LBK nr. 823 af 3. July 2007
- c) No. 743 af 23. September 1999
- d) AT No. 612 af 25. June 2008.

DS/EN

- a) 60335-1-A13-A14 General requirements
- b) 60335-2-40 Particular requirements for electrical heat pumps, air-conditioners and dehumidifiers
- c) 55014-1 Electromagnetic compatibility Part 1: Emission
- d) 55014-2 Electromagnetic compatibility Part 2: Immunity

| | | |
|---|---|---|
| Företag: Company: Firma: | Ort och datum: Place and date: Ort und Datum: | Underskrift: Signature: Unterschrift: |
| Nibe Energy Systems Hannabadvägen 5 SE-28521 Markaryd | Markaryd, 22. November 2013 |  Peter Jovic (PM Director) |
| | |  Kenneth Magnusson (Quality Manager) |

- (AT)** **KNV Energietechnik GmbH**, Gahberggasse 11, 4861 Schörfling
Tel: +43 (0)7662 8963-0 Fax: +43 (0)7662 8963-44 E-mail: mail@knv.at www.knv.at
-
- (CH)** **NIBE Wärmetechnik AG**, Winterthurerstrasse 710, CH-8247 Flurlingen
Tel: (52) 647 00 30 Fax: (52) 647 00 31 E-mail: info@nibe.ch www.nibe.ch
-
- (CZ)** **Druzstevni zavody Drazice s.r.o.**, Drazice 69, CZ - 294 71 Benatky nad Jizerou
Tel: +420 326 373 801 Fax: +420 326 373 803 E-mail: nibe@nibe.cz www.nibe.cz
-
- (DE)** **NIBE Systemtechnik GmbH**, Am Reiherpfahl 3, 29223 Celle
Tel: 05141/7546-0 Fax: 05141/7546-99 E-mail: info@nibe.de www.nibe.de
-
- (DK)** **Vølund Varmeteknik A/S**, Member of the Nibe Group, Brogårdsvej 7, 6920 Videbæk
Tel: 97 17 20 33 Fax: 97 17 29 33 E-mail: info@volundvt.dk www.volundvt.dk
-
- (FI)** **NIBE Energy Systems OY**, Juurakkotie 3, 01510 Vantaa
Puh: 09-274 697 0 Fax: 09-274 697 40 E-mail: info@nibe.fi www.nibe.fi
-
- (FR)** **AIT France**, 10 rue des Moines, 67500 Haguenau
Tel : 03 88 06 24 10 Fax : 03 88 06 90 15 E-mail: info@nibe.fr www.nibe.fr
-
- (GB)** **NIBE Energy Systems Ltd**, 3C Broom Business Park, Bridge Way, Chesterfield S41 9QG
Tel: 0845 095 1200 Fax: 0845 095 1201 E-mail: info@nibe.co.uk www.nibe.co.uk
-
- (NL)** **NIBE Energietechnik B.V.**, Postbus 634, NL 4900 AP Oosterhout
Tel: 0168 477722 Fax: 0168 476998 E-mail: info@nibenl.nl www.nibenl.nl
-
- (NO)** **ABK AS**, Brobekkveien 80, 0582 Oslo, Postadresse: Postboks 64 Vollebakk, 0516 Oslo
Tel. sentralbord: +47 23 17 05 20 E-mail: post@abkklima.no www.nibeenergysystems.no
-
- (PL)** **NIBE-BIAWAR Sp. z o. o.** Aleja Jana Pawła II 57, 15-703 BIAŁYSTOK
Tel: 085 662 84 90 Fax: 085 662 84 14 E-mail: sekretariat@biawar.com.pl www.biawar.com.pl
-
- (RU)** © **"EVAN"** 17, per. Boynovskiy, Nizhny Novgorod
Tel./fax +7 831 419 57 06 E-mail: info@evan.ru www.nibe-evan.ru
-

NIBE AB Sweden, Box 14, Hannabadvägen 5, SE-285 21 Markaryd
Tel: +46-(0)433-73 000 Fax: +46-(0)433-73 190 E-mail: info@nibe.se www.nibe.eu

